

## Chapter 2: Moving Pulsed Systems

There are three categories of pulsed system and we will consider each in turn. These are drive-pulsed systems, energy-tapping pulsed systems and gravity free-energy pulsing systems. Here we will look at systems where an electrical pulse is used to cause the device to operate by creating a temporary magnetic field caused by electric current flowing through a coil or "electromagnet" as it is often called. Many of these systems are rather subtle in the way that they operate. One very well-known example of this is

**The Adams Motor.** The late Robert Adams, an electrical engineer of New Zealand designed and built several varieties of electric motor using permanent magnets on the rotor and pulsed electromagnets on the frame of the motor (called the "stator" because it does not move). He found that if they were configured correctly, then the output from his motors exceeded their input power by a large margin (800%).



The diagram of his motor intended to show the basic operating principle is shown here:

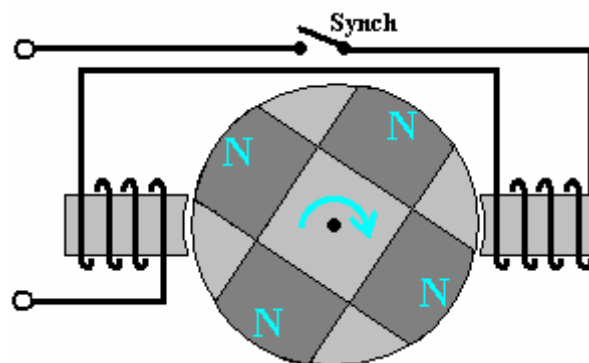

If a motor is built like this, then it will most certainly work but it will never reach 100% efficiency let alone exceeding the 100% mark. It is only with a specific configuration which is hardly ever publicised that high performance figures can be achieved. While Robert has shown several different configurations, in order to avoid confusion I will describe and explain just one of them. I am indebted to several of Robert's friends and colleagues for the following information and I should like to express my thanks to them for their help and support in bringing you this information.

First and foremost, high performance can only be achieved with the clever use of power collection coils. These coils need to be positioned accurately and their power collection restricted to just a very short arc of operation by connecting them to, and disconnecting them from, the output circuit at just the right instant so that the back EMF generated when the current draw stops, actually contributes to the drive of the rotor, speeding it on it's way and raising the overall efficiency of the motor/generator as a whole.

Next, the shape of the magnets used is important as the length to width proportion of the magnet alters the pattern of it's magnetic fields. In direct opposition to the diagram shown above, the magnets need to be much longer than their width (or in the case of cylindrical magnets, much longer than their diameter).

Further, a good deal of experimentation has shown that the size and shape of the electromagnets and pick-up coils has a major influence on the performance. The cross-sectional area of the core of the pick-up coils

should be four times that of the cross-sectional area of the permanent magnets in the rotor. The reverse is true for the cores of the drive coils as their cores should have a cross-sectional area of just one quarter of the rotor magnet cross-sectional area.

Another point which is almost never mentioned is the fact that big circuit gains will not be achieved unless the drive voltage is high. The minimum should be 48 volts but the higher the voltage, the greater the energy gain, so voltages in the 120 volts (rectified US mains voltage) to 230 volts (rectified mains voltage elsewhere) should be considered. Neodymium magnets are not recommended for drive voltages under 120 volts.

This is one of Robert's test circuits:

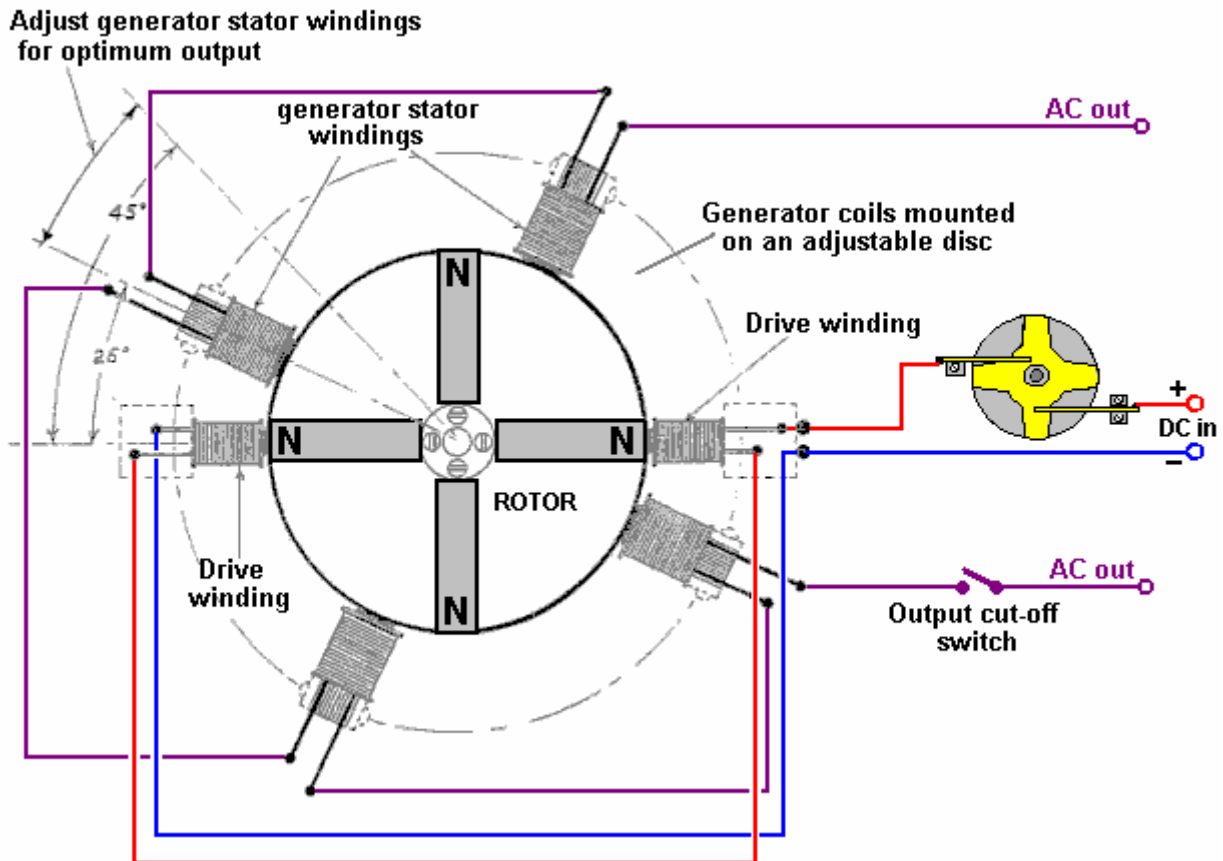

Notice that the cores of the "generator" pick-up coils are very much wider than the cores of the drive coils. Also notice the proportions of the magnets where the length is much greater than the width or diameter. The four generator windings are mounted on a single disc allowing them to be moved through an angle to find the optimum operating position before being locked in position and the two drive coils are mounted separately and held clear of the disc. Notice also that the power pick-up coils are much wider compared to their length than the drive coils are. This is a practical feature which is explained in greater detail later.

The DC input is shown passing through Robert's custom-made contactor switch which is mounted directly on the shaft of the motor/generator. This is a mechanical switch which allows an adjustable On / Off ratio, which is known as the "Mark/Space Ratio" or, if the "On" period is of particular interest, the "Duty Cycle". Robert Adams indicates that when the motor is running and has been adjusted to its optimum performance, then the Mark/Space ratio should be adjusted to minimise the On period and ideally get it down to about 25% so that for three quarters of the time, the input power is actually switched off. There are various ways of achieving this switching while still having a very sharp turn on and turn off of the power.

Robert considered mechanical switching of the drive current to be a very good option although he was not opposed to using the contact to power a transistor to do the actual switching and so reduce the current through the mechanical contacts by a major factor. His reasons for his preference for mechanical switching are that it gives very sharp switching, needs no electrical power to make it operate and it allows current to

flow in both directions. The current flow in two directions is important because Robert produced various ways of getting the motor to feed current back into the driving battery, allowing it to drive the motor for long periods without lowering its voltage hardly at all. His preferred method of switching is shown here:

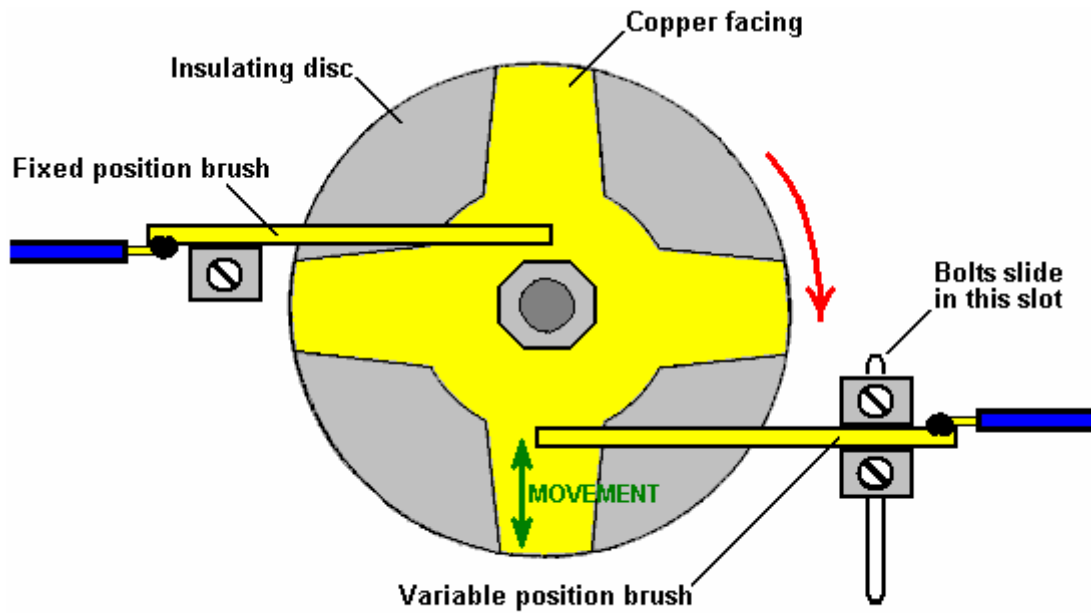

**TIMING GEAR - TOP VIEW**

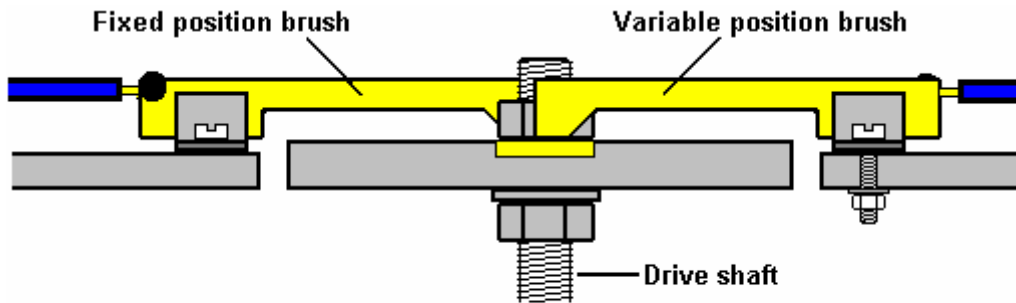

**TIMING GEAR - SIDE VIEW**

This switching gear operates as follows: The timing disk is bolted securely to the drive shaft of the motor and its position is set so that the electrical switch-on occurs when the rotor magnet is exactly aligned with the drive coil core. Adjustment of that timing is done by loosening the locking nut, rotating the disc very slightly and clamping the disc in position again. A spring washer is used to keep the assembly tight when the device is running. The disc has a star-shaped piece of copper sheet set into its surface and two silver-tipped, copper arm "brushes" slide across the surface of the copper star.

One of these two brushes is fixed in position and slides across the copper star near the drive shaft, making a permanent electrical connection to it. The second brush slides alternatively on the non-conducting surface of the disc and then over the conducting arm of the copper. The second brush is mounted so that its position can be adjusted and, because the copper arms taper, that alters the ratio of the "On" time to the "Off" time. The actual switching is achieved by current flowing through the first brush, through the copper arm and then through the second brush. The brush arms shown in the diagram above rely on the springiness of the copper arm to make a good brush-to-copper electrical connection. It might be preferred to use a rigid brush arm, pivot it and use a spring to ensure a very good contact between the brush and the copper star at all times.

The adjustment of the On to Off time, or "Mark/Space Ratio" or "Duty Cycle" as the technical people describe it, could perhaps do with some description. If the moveable brush is positioned near the centre of the disc, then, because of the tapering of the copper arms, the part of the non-conducting disc that it slides over is shorter and the part of the conducting copper arm with which it connects is longer, as the two sliding paths are about the same length, the current is on for about the same length as it is off, giving a Mark/Space ratio of about 50% as shown here:

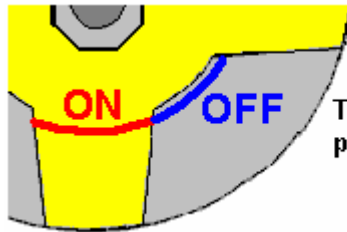

**The On path is about the same length as the Off path and so the Mark/Space ratio is about 50%**

If, instead, the moveable brush is positioned near the outside edge of the disc, then because of the tapering of the copper arm, the On path is shorter and the non-conducting Off path is very much longer, being about three times as long as the On path, giving a Mark/Space ratio of about 25%. As the moveable brush can be positioned anywhere between these two extremes, the Mark/Space ratio can be set to any value from 25% to 50%.

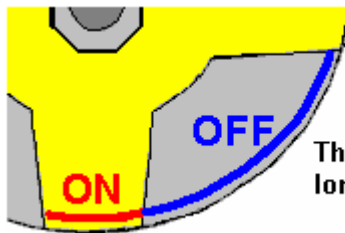

**The On path is shorter and the Off path is much longer giving a Mark/Space ratio of about 25%**

The two brushes can be on the same side of the drive shaft or on opposite sides as shown. One important feature is that the brushes touch in a position where the disc surface is always moving directly away from the brush mounting, causing any drag to be directly along the arm and giving no sideways loading on the brush. The diameter of the device is usually one inch (25 mm) or less.

You will also notice that the output is switched although the diagram does not give any indication of how or when that switching takes place. You will notice that the diagram has angles marked on it for the optimum positioning of the pick-up coils, well, an Adams Motor builder with a forum ID of "Maimariati" who achieved a Coefficient Of Performance of 1,223, found that the optimum switching for his motor is On at 42 degrees and Off at 44.7 degrees. That tiny 2.7 degree part of the rotor turn gives a substantial power output and cutting the output current off at that point causes the back EMF of the coils to give the rotor a substantial additional boost on its way. His input power is 27.6 watts and his output power is 33.78 kilowatts

Now for some practical details. It is suggested that a good length for the power pick-up coils can be determined by using the "paper clip test". This is done by taking one of the permanent magnets used in the rotor, and measuring the distance at which that magnet just begins to lift one end of a 32 mm (1.25 inch) paper clip off the table. The optimum length of each coil from end to end is exactly the same as the distance at which the paper clip starts to lift.

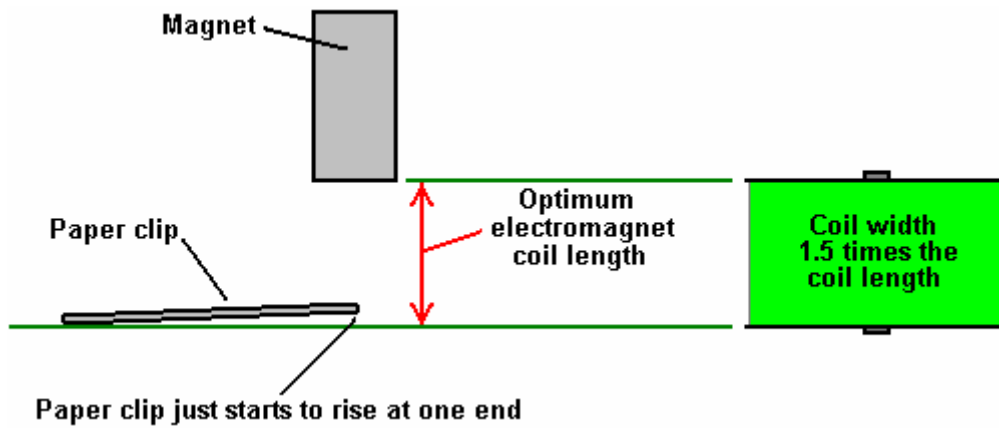

The core material used in the electromagnets can be of various different types including advanced materials and alloys such as 'Somalloy' or 'Metglas'. The power pick-up coil proportions are important as an electromagnet becomes less and less effective as its length increases, and eventually, the part furthest from the active end can actually be a hindrance to the effective operation. A good coil shape is one which you would not expect, with the coil width being, perhaps 50% greater than the coil length:

Contrary to what you would expect, the device draws in energy from the local environment better if the end of the pick-up coil farthest from the rotor is left unaffected by any other part of the device and the same applies to the magnet facing it. That is, the coil should have the rotor at one end and nothing at the other end, that is, no second rotor behind the coil. The speed at which the voltage is applied to, and removed from, the coils is very important. With very sharp voltage rises and falls, additional energy is drawn from the surrounding environmental energy field. If using transistor switching, then the IRF3205 FET has been found to be very good and a suitable driver for the FET is the MC34151.

If using a Hall-effect semiconductor to synchronise the timing, say the UGN3503U which is very reliable, then the life of the Hall-effect device is much improved if it is provided with a 470 ohm resistor between it and the positive supply line, and a similar 470 ohm resistor between it and the negative line. These resistors in series with the Hall-effect device effectively "float" it and protect it from supply-line spikes".

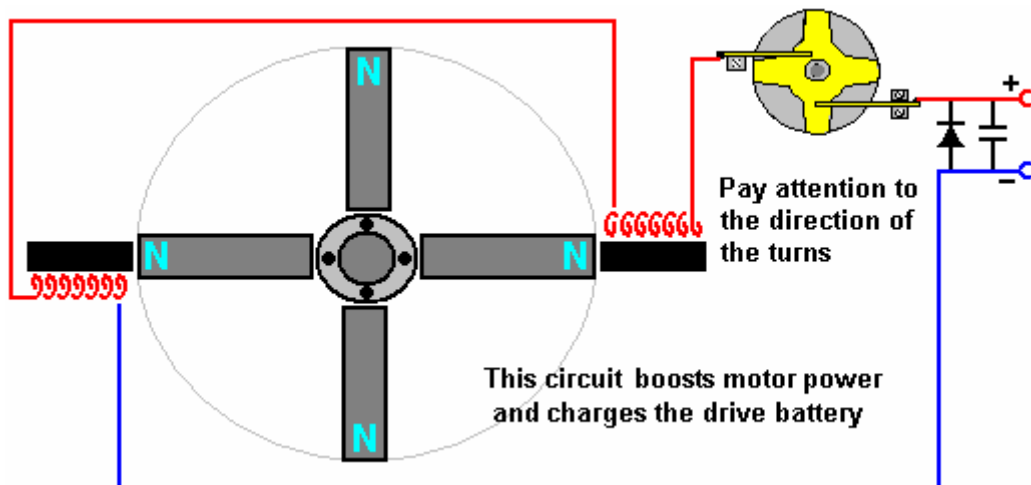

Here, two electromagnets are driven by the battery via Robert's 4-arm commutator which is mounted on the rotor shaft. Some of the recommendations given by Robert are the opposite of what you would expect. For example, he says that a single rotor construction tends to be more electrically efficient than one where several rotors are mounted on a single shaft. Robert is against the use of reed switches and he recommends making one of his commutators.

At one stage, Robert recommended the use of standard transformer shims for constructing the cores of the electromagnets. This has the advantage that matching bobbins for holding the coil windings are readily available and can still be used for pick-up coils. Later on, Robert swung towards the use of solid cores from the old PO Series 3000 telephone relays and eventually said that electromagnet cores should be solid iron.

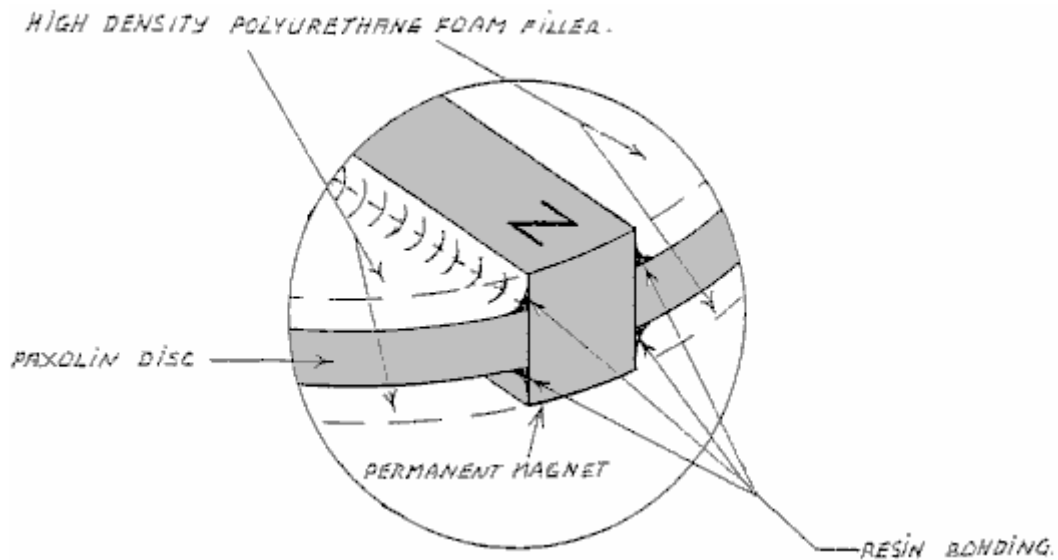

The diagrams presented by Robert show the magnets located on the rim of the rotor and pointing outwards. If this is done, then it is essential that the magnets in the rotor are firmly attached on at least five of their six faces and the possibility of using a ring of non magnetic material such as duct tape around the outside should be considered. That style of construction also lends itself to streamlining the rotor by having a completely solid construction, although it might be remarked that the motor would run better and more quietly if it were enclosed in a box which had the air pumped out of it. If that is done, then there will be no air resistance and because sound can't pass through a vacuum, quieter operation is bound to result.

While this may sound a bit complicated, there is no reason why it should be. All that is needed is two discs and one central disc which is the thickness of the magnets, with slots cut in it, the exact size of the magnets. The assembly starts with the lower disc, magnets and central disc. These are glued together, probably with epoxy resin, and that holds the magnets securely on four faces as shown here:

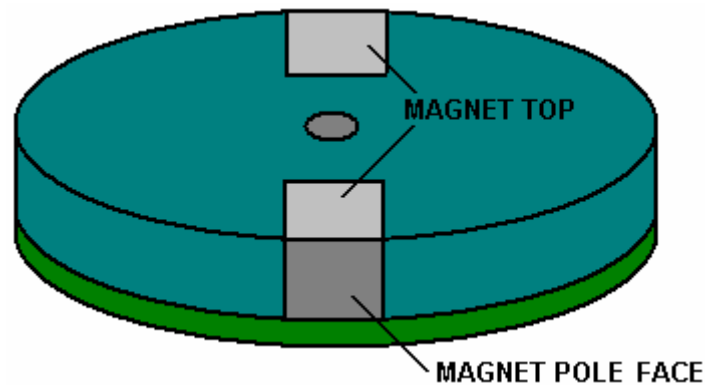

Here, the magnets are attached on the lower face, the right and left faces, and the unused pole face, and when the upper disc is attached, the upper faces are also secured and there is the minimum of air turbulence when the rotor spins:

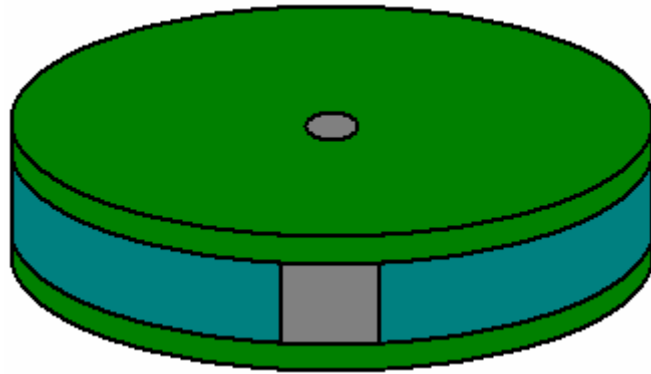

There is a "sweet spot" for the positioning of the power pick-up coils and it will usually be found that this is two or three millimeters away from the rotor. If that is the case, then there will be room for an outer band of duct tape on the rim of the rotor to provide additional protection against the failure of the magnet attachment method.

High-power versions of the motor/generator need to be enclosed in a metal box which is earthed as they are quite capable of generating a substantial amount of high frequency waves which can damage equipment such as oscilloscopes and create TV reception interference. There would probably be an improvement in performance as well as a reduction in sound if the box was airtight and had the air pumped out of it. If that is done, then there will be no air resistance as the rotor spins and since sound does not pass through a vacuum, quieter operation is possible.

Experienced rotor builders do not like the radial magnets style of construction because of the stresses on the magnet attachments if high rotational speeds are reached. It should not need to be said, but it is obviously a major requirement to keep your hands well away from the rotor when the motor is running as it is perfectly possible to be injured by the high-speed movement if you are careless. Please remember that this presentation must not be considered to be a recommendation that you build or use any device of this nature and it must be stressed that this text, in common with the entire contents of this eBook, is intended to be for information purposes only and no representations or warranties are implied by this presentation. Should you decide to construct, test or use any device, then you do so entirely at your own risk and no liability attaches to anybody else if you sustain any kind of injury or property damage as a result of your own actions.

Because of the mechanical stresses caused during rotation, some experienced constructors feel that the magnets should be embedded in the rotor as shown here where they are kept well clear of the rim of a rotor which is made from a tough material. This is so that the outer strip of the material prevents the magnets breaking loose and becoming dangerous high-speed projectiles, which at best would destroy the electromagnets and at worst could injure someone quite badly:

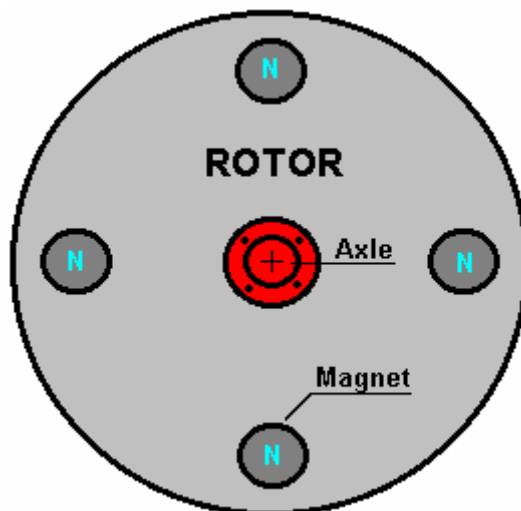

It needs to be remembered that the proportions of the magnets are for the magnet length to be more than the diameter, so in cases like this where circular magnet faces are to be used, the magnets will be cylindrical and the rotor needs to have a significant thickness, which will depend on the magnets which are available locally. The magnets should be a tight push-fit in their holes and securely glued in place.

Robert Adams has used this construction style as well. However, if an arrangement like this is used, then there will be a substantial sideways pull on the rotor as it reaches the electromagnet core, tending to pull the magnets out of the rotor.

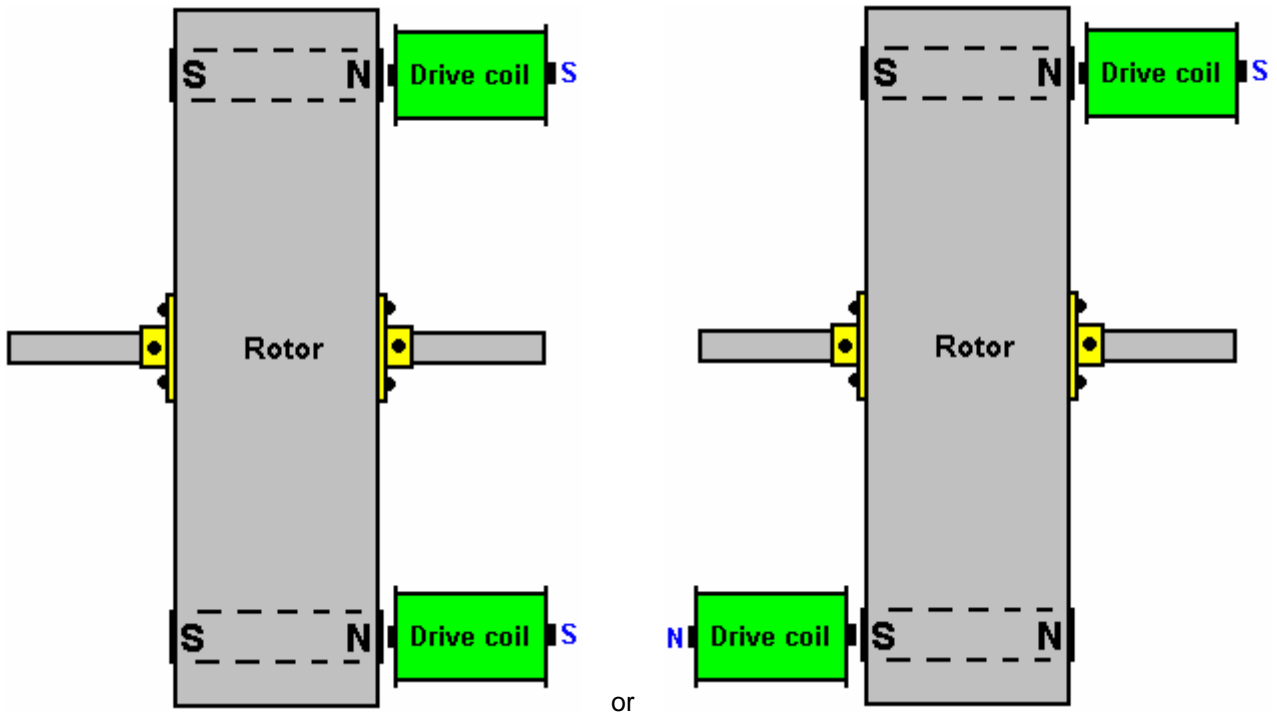

It is important that the rotor should be perfectly balanced and have the minimum amount of bearing friction possible. This calls for precision construction and either roller or ball bearings. The construction style shown above has the distinct advantage that it has an open end to both the magnet and the coils and this is believed to facilitate the inflow of environmental energy into the device.

It may be my ignorance showing here, but I have a problem with the version on the right (which is considered by some to be the optimum arrangement). The difficulty as I see it is that the magnet/core pull and the subsequent drive thrust when the coil is powered, form a "turning couple" as they both tend to rotate the axle in the same direction. This places a substantial loading on the axle bearings, usually amplified by the radius of the rotor being greater than the distance from the rotor to the axle bearings. This load will be in the tens of kilograms range and will be applied and reversed perhaps forty times per second. To me, that appears like a vibration load and is directly opposed to the "perfectly balanced" rotor operation being sought. The radial magnet arrangement generally shown by Robert Adams does not have any of this kind of loading at all because the coils are exactly opposite each other and their loads cancel each other out exactly. The choice is, of course, up to the builder and his assessment of the advantages and disadvantages of the different styles of construction.

When getting ball-race bearings for an application like this, please be aware that "closed" bearings such as these are not suitable as supplied:





This is because this type of bearing is usually packed with dense grease which completely destroys its free motion, making it worse as a bearing than a simple hole-and-shaft arrangement. However, in spite of this, the closed or "sealed" bearing is popular as the magnets tend to attract dirt and dust and if the device is not enclosed in a steel box as is necessary for the high power versions, then having the seal is considered to be an advantage. The way to deal with the grease packing is to soak the bearing in an isopropyl solvent cleaner to remove the manufacturer's grease, and then, when it has dried out, lubricate the bearing with two drops of a high quality thin oil. If it is intended to house the motor/generator in an earthed, sealed steel box then an alternative type of bearing which might be suitable is an open design like this:



especially if the air is removed from the box. Some constructors prefer to use ceramic bearings which are supposed to be immune to dirt. One supplier is <http://www.bocabearings.com/main1.aspx?p=docs&id=16> but as with everything else, these choices have to be made by the builder and will be influenced by his opinions.

I'm not sure where it came from, but here is a circuit diagram showing a transistor drive and the return of the back EMF of the drive coils to the driving power supply. Using this method, about 95% of the drive current can be returned, lowering the current draw enormously:

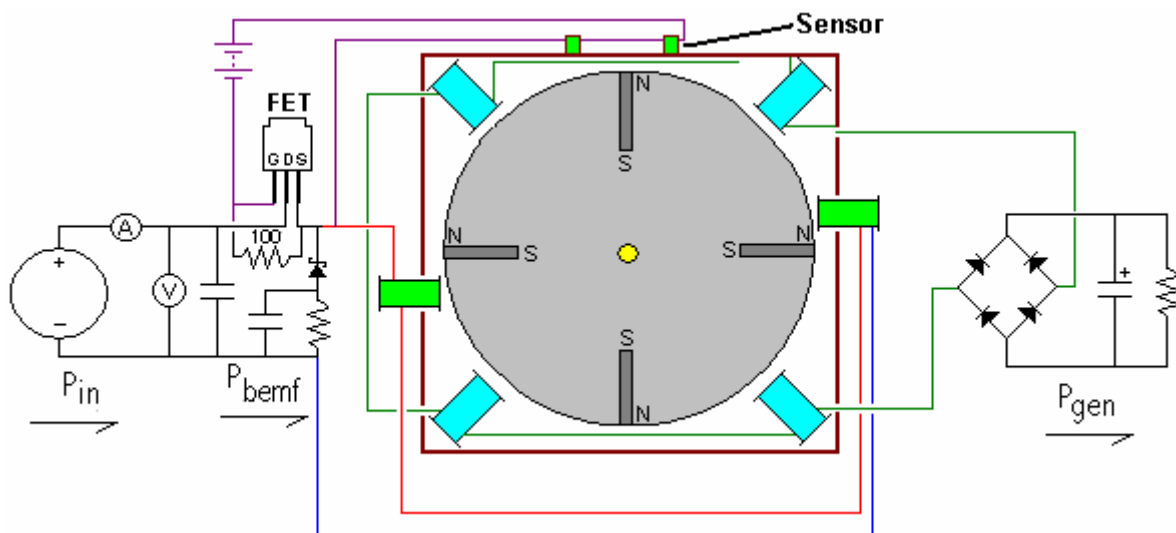

The diode feeding the power back to the supply is a Schottky type because of its high-speed operation. It needs to be able to handle the peak pulse power and so should be one of the more robust types. What this circuit does not have is the very important switching on the output coils circuit. Another strange item is the way that the FET sensor is arranged with two sensors rather than one and with an additional battery. While it must be admitted that the current draw of the FET gate should be very low, there still does not seem to be much reason to have a second power supply. One other peculiarity in this diagram is the positioning of the drive coils. With them offset as shown, it has the effect of them being at an angle relative to the rotor magnets. It is not at all clear if this is an advanced operating technique or just poor drawing - I am inclined to

assume the latter although I have no evidence for this other than the circuit design and the low quality of the original drawing which had to be improved considerably to arrive at the diagram shown above.

The coil generator output should be fed into a capacitor before being passed to whatever equipment is to be powered by the device. This is because the energy is being drawn from the local environment and is not conventional energy. Storing it in a capacitor converts it to a more normal version of electrical power, a feature which has also been mentioned by Don Smith and by John Bedini although their devices are quite different in operation.

The DC resistance of the coil windings is an important factor. The overall resistance should be either 36 ohms or 72 ohms for a complete set of coils, whether they are drive coils or power pick-up coils. Coils can be wired in parallel or in series or in series/parallel. So, for 72 ohms with four coils, the DC resistance of each coil could be 18 ohms for series-connected, 288 ohms for parallel connected, or 72 ohms for connection in series/parallel where two pairs of coils in series are then wired in parallel.

To help with assessing the wire diameter and length which you could use, here is a table of some of the common sizes in both American Wire Gage and Standard Wire Gauge:

AWG	Dia mm	SWG	Dia mm	Max Amps	Ohms / 100 m
11	2.30	13	2.34	12	0.53
12	2.05	14	2.03	9.3	0.67
13	1.83	15	1.83	7.4	0.85
14	1.63	16	1.63	5.9	1.07
15	1.45	17	1.42	4.7	1.35
16	1.29	18	1.219	3.7	1.70
18	1.024	19	1.016	2.3	2.7
19	0.912	20	0.914	1.8	3.4
20	0.812	21	0.813	1.5	4.3
21	0.723	22	0.711	1.2	5.4
22	0.644	23	0.610	0.92	6.9
23	0.573	24	0.559	0.729	8.6
24	0.511	25	0.508	0.577	10.9
25	0.455	26	0.457	0.457	13.7
26	0.405	27	0.417	0.361	17.4
27	0.361	28	0.376	0.288	21.8
28	0.321	30	0.315	0.226	27.6
29	0.286	32	0.274	0.182	34.4
30	0.255	33	0.254	0.142	43.9
31	0.226	34	0.234	0.113	55.4
32	0.203	36	0.193	0.091	68.5
33	0.180	37	0.173	0.072	87.0
34	0.160	38	0.152	0.056	110.5
35	0.142	39	0.132	0.044	139.8

So far, we have not discussed the generation of the timing pulses. A popular choice for a timing system is to use a slotted disc mounted on the rotor axle and sensing the slots with an "optical" switch. The "optical" part of the switch is usually performed by UV transmission and reception and as ultra violet is not visible to the human eye, describing the switching mechanism as "optical" is not really correct. The actual sensing mechanism is very simple as commercial devices are readily available for performing the task. The sensor housing contains both a UV LED to create the transmission beam, and a UV dependent resistor to detect that transmitted beam.

Here is an example of a neatly constructed timing mechanism made by Ron Pugh for his six-magnet rotor assembly:

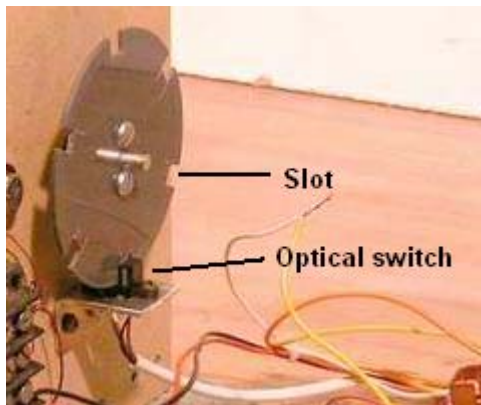

and the switch/sensor:

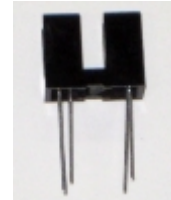

This device happens to be one which is supplied by [www.bayareaamusements.com](http://www.bayareaamusements.com) under their product code number : OP-5490-14327-00. As the slotted disc rotates, one of the slots comes opposite the sensor and allows the UV beam to pass through to the sensor. That lowers the resistance of the sensor device and that change is then used to trigger the drive pulse for whatever length of time the slot leaves the sensor clear. You will notice the balanced attachment method used by Ron to avoid having an unbalanced rotor assembly. There can be two timing discs, one for the drive pulses and one for switching the power pickup coils in and out of the circuit. The slots in the power pick-up timing disc will be very narrow as the switch-on period is only about 2.7 degrees. For a six-inch diameter disc where 360 degrees represents a circumference length of 18.85 inches (478.78 mm) a 2.7 degree slot would be only 9/64 inch (3.6 mm) wide. The arrangement for an axial magnet rotor set-up could be like this:

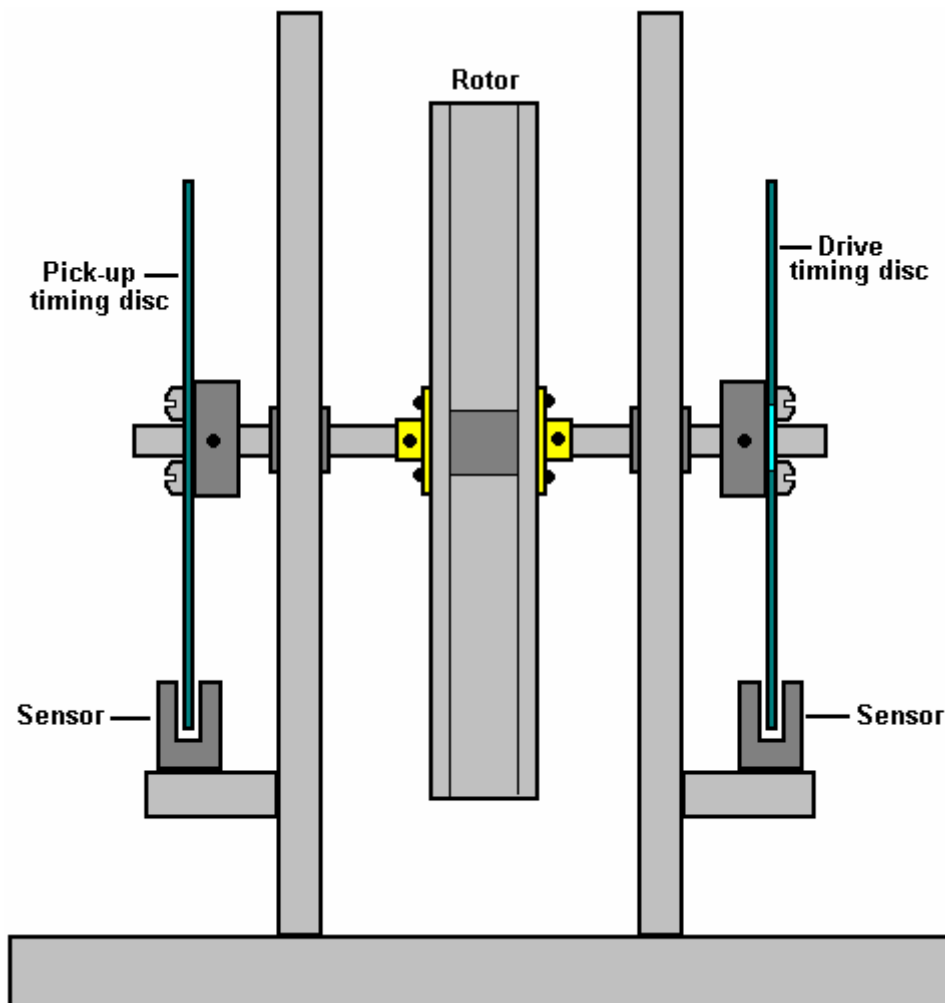

So to recap, the things which are necessary for getting an Adams Motor output into the serious bracket are:

1. A performance of COP>1 can only be achieved if there are power pick-up coils.
2. The rotor magnets need to be longer than they are wide in order to ensure the correct magnetic field shape and the rotor must be perfectly balanced and have bearings as low-friction as possible.
3. The face area of the rotor magnets needs to be four times that of the drive coil cores and one quarter the area of the core of the power pick-up coils. This means that if they are circular, then the drive coil core diameter needs to be half the diameter of the magnet and the magnet diameter needs to be half the diameter of the power pick-up core. For example, if a circular rotor magnet is 10 mm across, then the drive core should be 5 mm across and the pick-up core 20 mm across.
4. The drive voltage needs to be a minimum of 48 volts and preferably, a good deal higher than that.
5. Do not use neodymium magnets if the drive voltage is less than 120 volts.
6. The drive coils should not be pulsed until they are exactly aligned with the rotor magnets even though this does not give the fastest rotor speed.
7. Each complete set of coils should have a DC resistance of either 36 ohms or 72 ohms and definitely 72 ohms if the drive voltage is 120 volts or higher.
8. Collect the output power in large capacitors before using it to power equipment.

If you want the original drawings and some explanation on the operation of the motor, then two publications from the late Robert Adams can be bought from [www.nexusmagazine.com](http://www.nexusmagazine.com) where the prices are quoted in Australian dollars, making the books look much more expensive than they actually are.

The web site <http://members.fortunecity.com/freeenergy2000/adamsmotor.htm> is a location for Adams motor enthusiasts and may have information which might be helpful.

<http://www.totallyamped.net/adams/index.html> is a really impressive collection of well-informed practical material on building and using an Adams motor with details of sensors and how they work, core materials and their performances and how to locate the "sweet spot" - very highly recommended web site.

**Raymond Kromrey.** Where the objective is to produce electricity from a rotating magnetic field, there has always been a search for some method of either reducing, or eliminating altogether, the drag on the rotor when electric current is drawn from the generator. One design which claims to have very limited drag caused by current draw is the Kromrey design. The main characteristics of this design are said to be:

1. It has almost constant electrical power output even when the rotor speed is altered by as much as 35%.
2. It can continue to operate with it's electrical output short-circuited, without heating the rotor or causing a braking effect.
3. The production efficiency (electrical output divided by the driving force) is high.
4. The frequency of it's AC output power can be adjusted to that required by the equipment which it powers.
5. The rotor can be spun at any rate from 800 rpm to 1,600 rpm.
6. The simple construction allows manufacturing costs to be about 30% less than other generators.
7. This generator is recommended for supplying power at or above the 1 kilowatt level.

Here is the patent for this device:

**Patent US 3,374,376**

**19th March 1968**

**Inventor: Raymond Kromrey**

### **ELECTRIC GENERATOR**

My present invention relates to an electric generator which converts magnetic energy into electric energy using two components which can rotate relative to each other, i.e. a stator and a rotor, one having electromagnets or permanent magnets which induce a voltage in a winding which forms part of an output circuit mounted on the other component.

Conventional generators of this type use a winding which whose conductors form loops in different axial planes so that opposite parts of each loop pass through the field of each pole pair, twice per revolution. If the loops are open circuit, then no current flows in the winding and no reaction torque is developed, leaving the rotor free to turn at the maximum speed of its driving unit. As soon as the output winding is connected across a load or is short-circuited, the resulting current flow tends to retard the motion of the rotor to an extent which depends on the intensity of the current and this makes it necessary to include compensating speed-regulating devices if it is necessary to maintain a reasonably constant output voltage. Also, the variable reaction torque subjects the rotor and its transmission to considerable mechanical stresses and possible damage.

It is therefore the general object of this invention to provide an electric generator which has none of the above disadvantages. Another object is to provide a generator whose rotor speed varies very little in speed between open circuit operation and current delivery operation. Another objective is to provide a generator whose output voltage is not greatly affected by fluctuations in its rotor speed.

I have found that these objectives can be achieved by rotating an elongated ferromagnetic element, such as a bar-shaped soft-iron armature, and a pair of pole pieces which create an air gap containing a magnetic field. Each of the outer extremities of the armature carries a winding, ideally, these windings are connected in series, and these coils form part of a power output circuit used to drive a load. As the armature rotates relative to the air gap, the magnetic circuit is intermittently completed and the armature experiences periodic remagnetisations with successive reversals of polarity.

When the output circuit is open, the mechanical energy applied to the rotor (less a small amount needed to overcome the friction of the rotating shaft) is absorbed by the work of magnetisation, which in turn, is dissipated as heat. In actual practice however, the resulting rise in temperature of the armature is hardly noticeable, particularly if the armature is part of the continuously air-cooled rotor assembly. When the output circuit is closed, part of this work is converted into electrical energy as the current flow through the winding opposes the magnetising action of the field and increases the apparent magnetic reluctance of the armature, and so the speed of the generator remains substantially unchanged if the output circuit is open or closed.

As the armature approaches its position of alignment with the gap, the constant magnetic field tends to accelerate the rotation of the armature, aiding the applied driving force. After the armature passes through the gap there is a retarding effect. When the rotor picks up speed, the flywheel effect of its mass overcomes these fluctuations in the applied torque and a smooth rotation is experienced.

In a practical embodiment of this invention, the magnetic flux path includes two axially spaced magnetic fields traversing the rotor axis and substantially at right angles to it. These fields are generated by respective pole pairs co-operating with two axially spaced armatures of the type already described. It is convenient to arrange these two armatures so that they lie in a common axial plane and similarly, the two field-producing pole pairs also lie in a single plane. The armatures should be laminated to minimise eddy currents, so they are made of highly permeable (typically, soft-iron) foils whose principle dimension is perpendicular to the rotor axis. The foils can be held together by rivets or any other suitable method.

If the ferromagnetic elements are part of the rotor, then the output circuit will include the usual current-collecting means, such as slip-rings or commutator segments, depending on whether AC or DC current output is desired. The source of coercive force in the stator includes, advantageously, a pair of oppositely

positioned, yoke-shaped magnets of the permanent or electrically energised type, whose extremities constitute the pole pieces mentioned above. If electromagnets are used in the magnetic circuit, then they may be energised by an external source or by direct current from the output circuit of the generator itself.

I have found that the terminal voltage of the output circuit does not vary proportionately to the rotor speed as might be expected, but instead, it drops at a considerably slower rate with decreasing rotor speed. So, in a particular tested unit, this voltage fell to only about half its original value when the rotor speed was dropped to one third. This non-linear relationship between terminal voltage and driving rate produces a substantially constant load current and therefore, electric output over a wide speed range, at least under certain load conditions, inasmuch as the inductive reactance of the winding is proportional to frequency (and consequently, to rotor speed) so as to drop off more rapidly than the terminal voltage, in the event of a speed reduction, with a resulting improvement in the power factor of the load circuit.

If the magnetic circuit contains only a single pole pair per air gap, the flux induced in the rotating armature will change its direction twice per revolution so that each revolution produces one complete cycle of 360 electrical degrees. In general, the number of electrical degrees per revolution will equal 360 times the number of pole pairs, it being apparent that this number ought to be odd since with even numbers it would not be possible to have poles alternating in polarity along the path of the armature and at the same time to have the North and South poles of each pair at diametrically opposite locations. In any case, it is important to dimension the curved facing faces of the pole pairs in such a manner so as to avoid allowing the armature to bridge between adjoining poles, so it is necessary to make the sum of the arcs spanned by these faces (in the plane of rotation) equal to considerably less than 360 degrees electrical.

The invention will now be described in more detail, reference being made to the accompanying drawings in which:

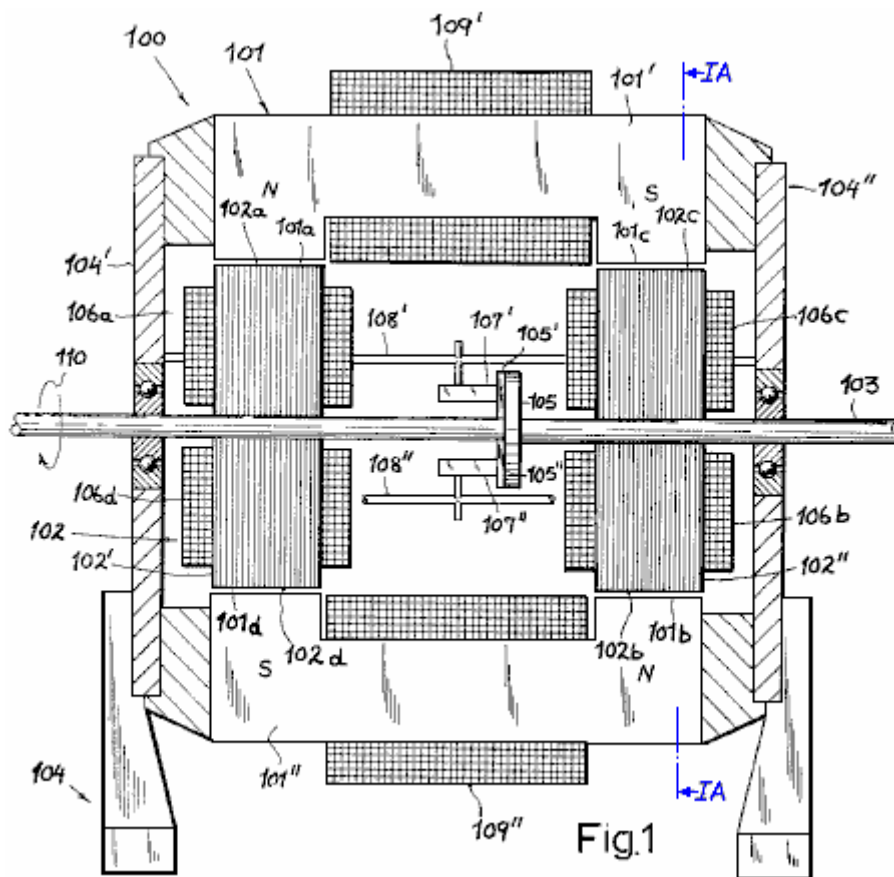

**Fig.1** and **Fig1A**. illustrate a first embodiment of my invention, shown in axial section and in a cross-sectional view taken on line IA - IA of Fig.1 respectively.

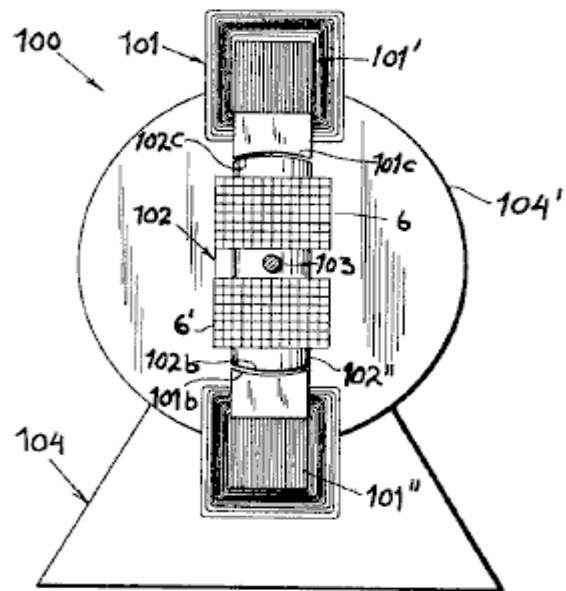

Fig.1A

Fig.2 and Fig.3 are perspective views illustrating two other embodiments.

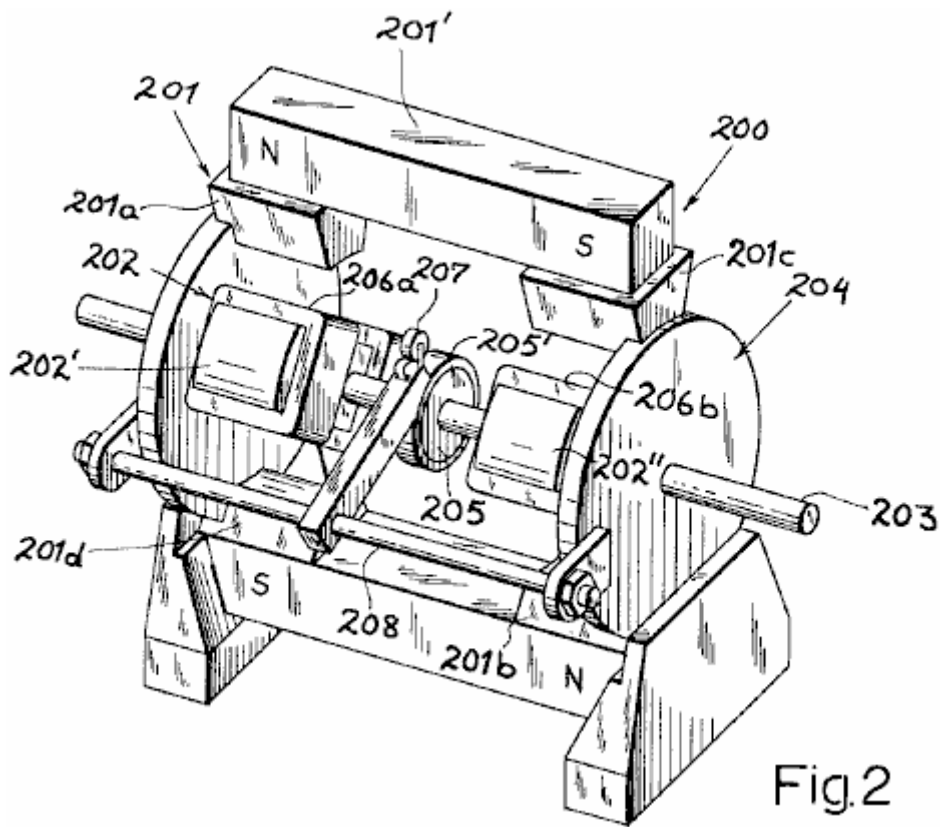

Fig.2

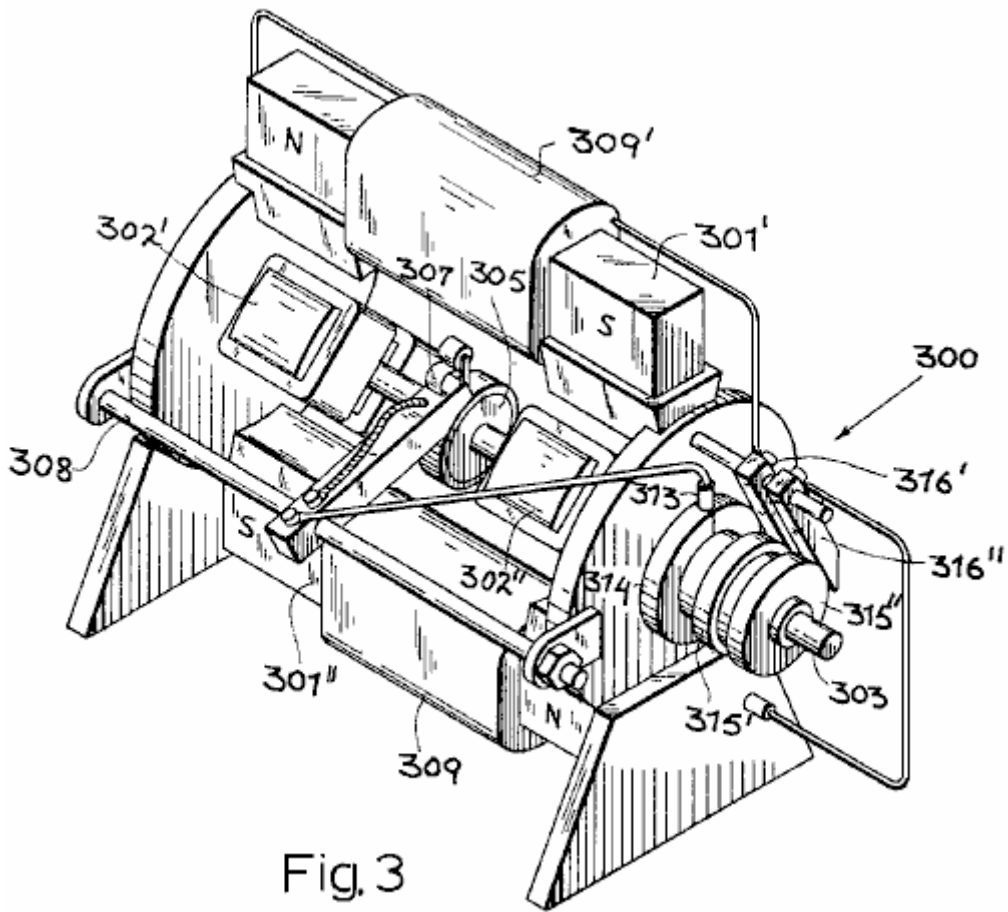

Fig. 3

Fig. 4 and Fig. 5 illustrate diagrammatically, two output circuit arrangements, one for a DC output and one for an AC output.

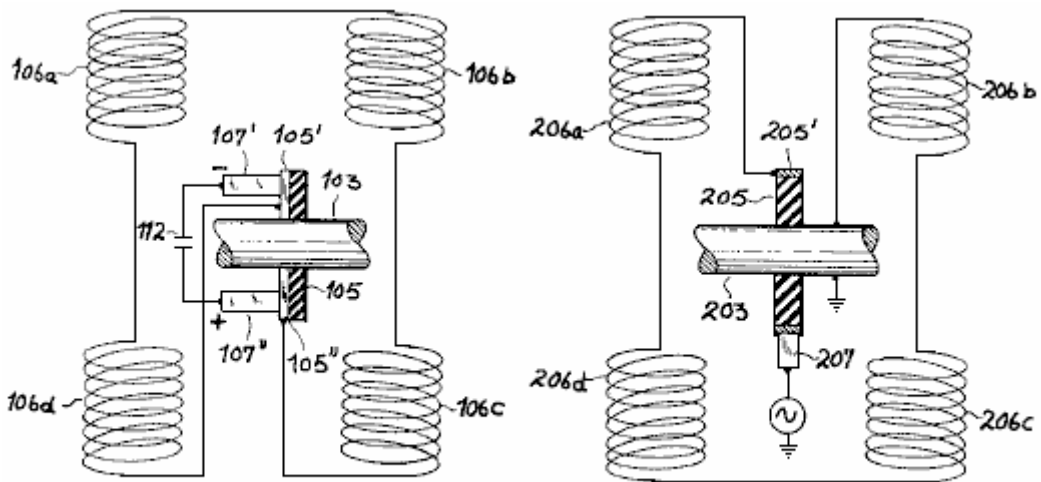

Fig 4

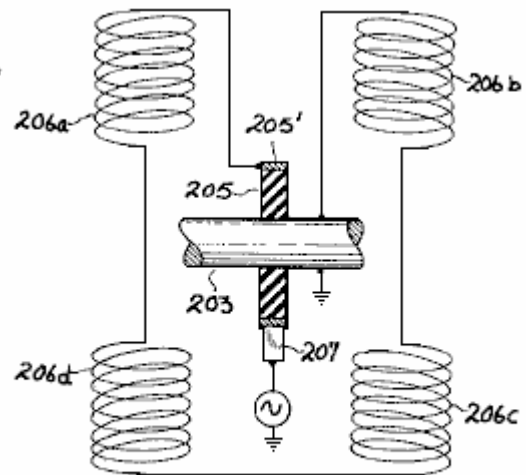
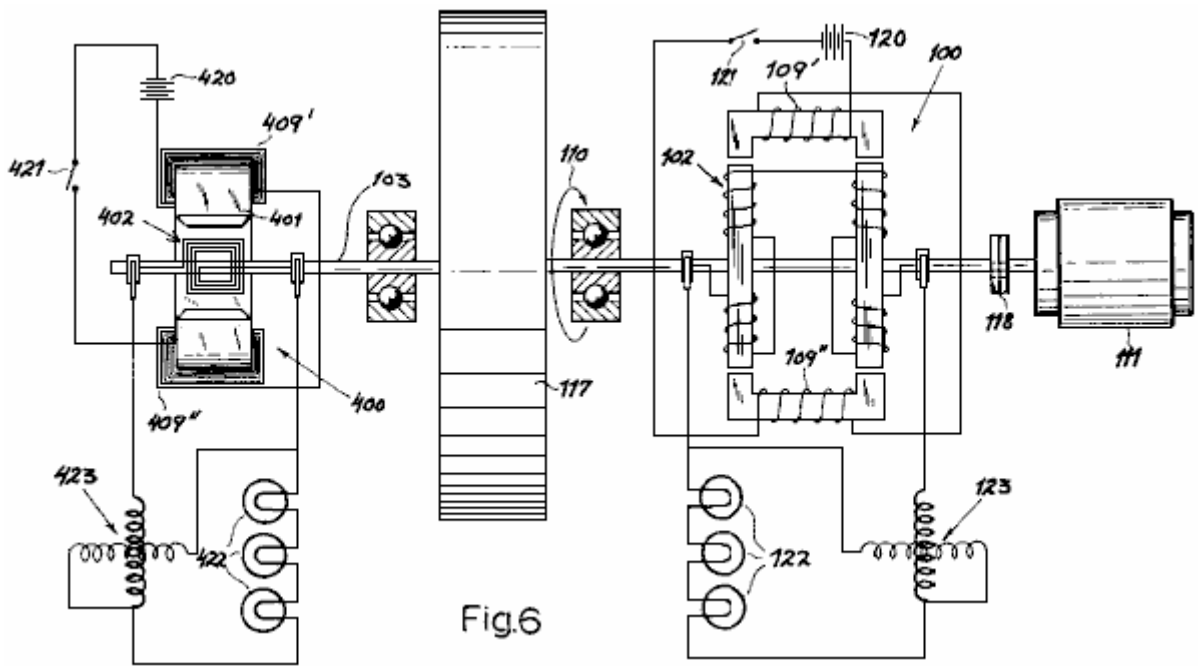

Fig 5

Fig. 6 is a somewhat diagrammatic illustration of an arrangement for comparing the outputs of a conventional generator and a generator according to this invention.





The generator **100** shown in **Fig.1** and **Fig.1A** comprises a stator **101** and a rotor **102** which has a pair of laminated armatures **102'** and **102''**, carried on a shaft **103** which is free to rotate in bearings mounted in the end plates **104'** and **104''**, of a generator housing **104** which is made from non-magnetic material (e.g. aluminium) which is rigidly attached to the stator.

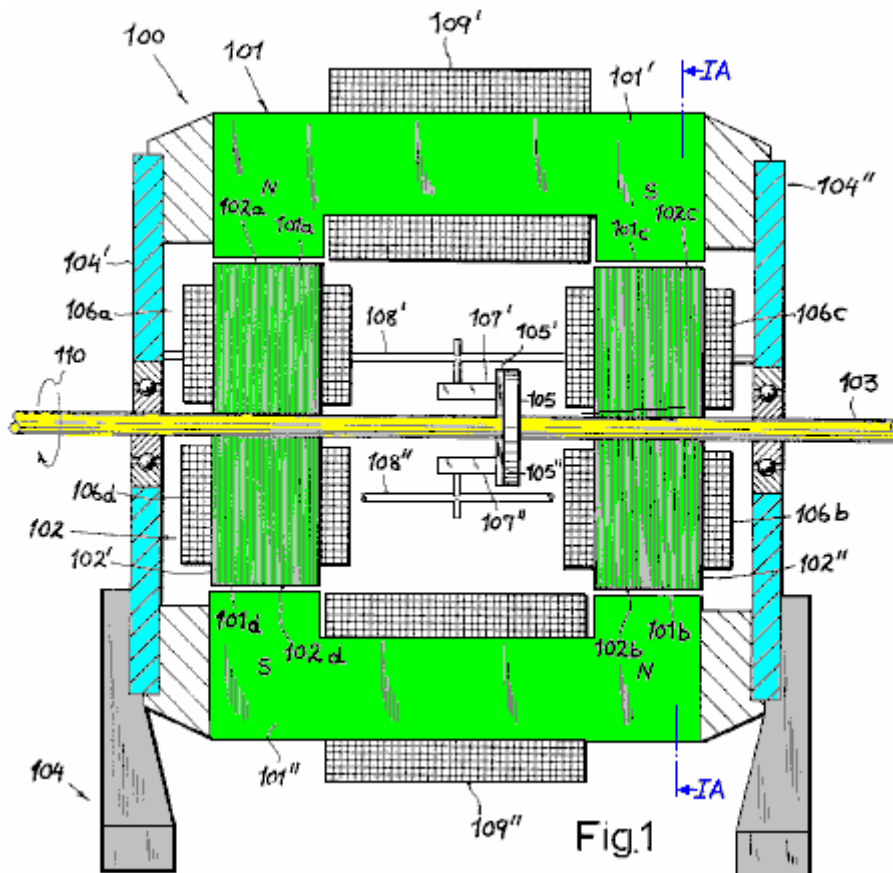

Shaft **103** is coupled to a source of driving power indicated diagrammatically by an arrow **110**. The stator **101** includes a pair of yoke-shaped laminated electromagnets **101'** and **101''** whose extremities form two pairs of co-planar pole pieces, designated respectively **101a**, **101b** (North magnetic pole) and **101c**, **101d**

(South magnetic pole). The pole pieces have concave faces, facing towards the complimentary convex faces **102a, 102d** of armature **102'** and **102b, 102c** of armature **102''**. These faces whose concavities are all centred on the axis of shaft **103**, extend over arcs of approximately  $20^{\circ}$  to  $25^{\circ}$  each in the plane of rotation (**Fig.1A**) so that the sum of these arcs adds up to about  $90^{\circ}$  geometrically and electrically.

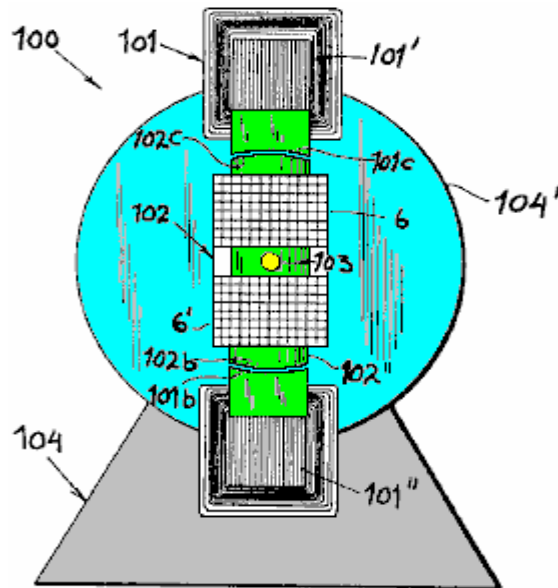

Fig.1A

The stator magnets **101', 101''** are surrounded by energising windings **109', 109''** which are connected across a suitable source of constant direct current (not shown). Similar windings, each composed of two series-connected coils **106a, 106d** and **106b, 106c**, surround the rotor armatures **102'** and **102''**, respectively. These coils form part of an output circuit which further includes a pair of brushes **107', 107''** which are carried by arms **108', 108''** on housing **104** with mutual insulation brushes **107', 107''** co-operate with a pair of commutator segments **105', 105''** (see also **Fig.4**) which are supported by a disc of insulating material **105**, mounted on shaft **103**.

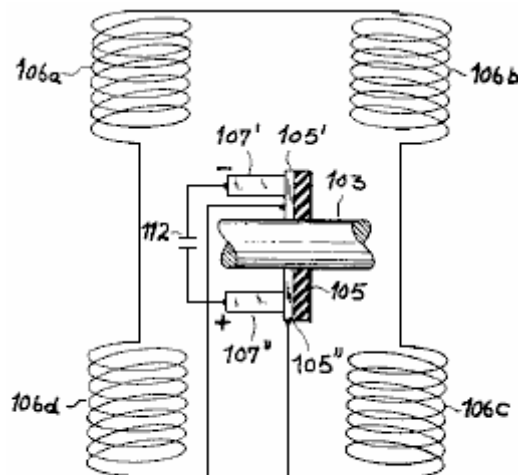

Fig.4

By virtue of the series-connection of coils **106a-106d** between the segments **105'** and **105''**, as illustrated in **Fig.4**, the alternating voltage induced in these coils gives rise to a rectified output voltage at brushes **107'** and **107''**. The unidirectional current delivered by these brushes to a load (not shown) may be smoothed by conventional means, represented by capacitor **112** in **Fig.4**.

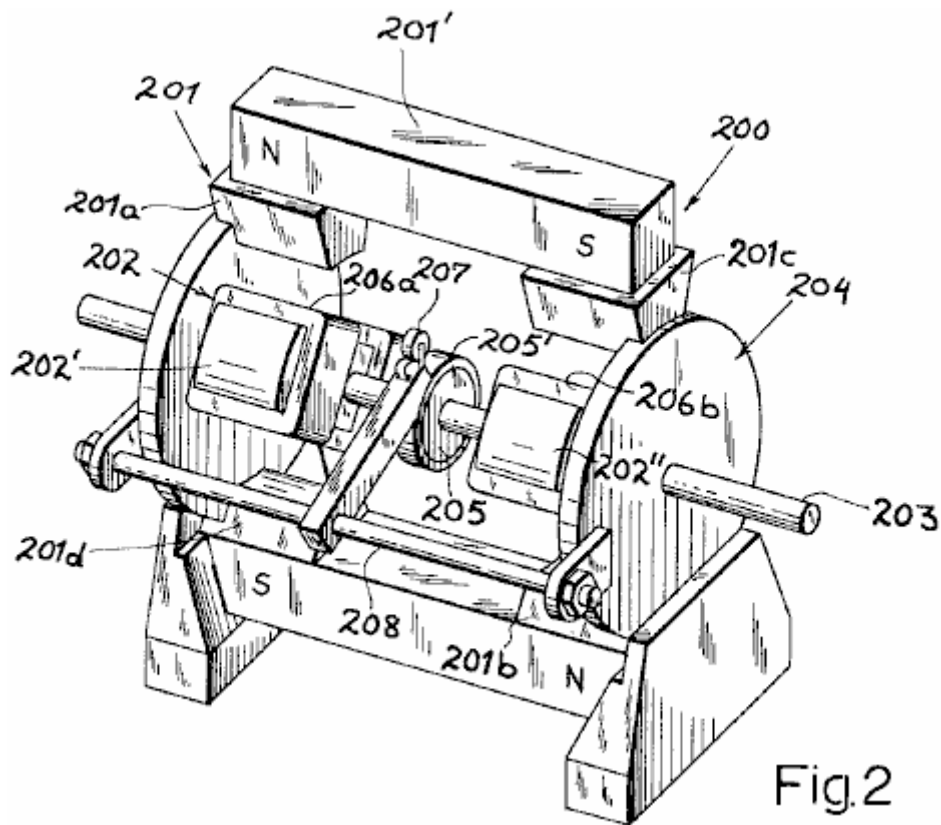

Fig.2

**Fig.2**, shows a modified generator **200**, whose housing **204**, supports a stator **201** essentially consisting of two permanent bar magnets **201'** and **201''**, extending parallel to the drive shaft **203** (on opposite side of it), each of these magnets being rigid and each having a pair of sole shoes **201a**, **201c** and **201b**, **201d** respectively. Rotor **202** is a pair of laminated armatures **202'** and **202''**, similar to those of the previous embodiment, whose output coils **206a**, **206b**, **206c** and **206d** are serially connected between a slip-ring **205'**, supported on shaft **203** through the intermediary of an insulating disc **205**, and another terminal here represented by the grounded shaft **203** itself. Slip-ring **205'** is contacted by brush **207** on holder **208**, the output of this brush being an alternating current of a frequency determined by the rotor speed.

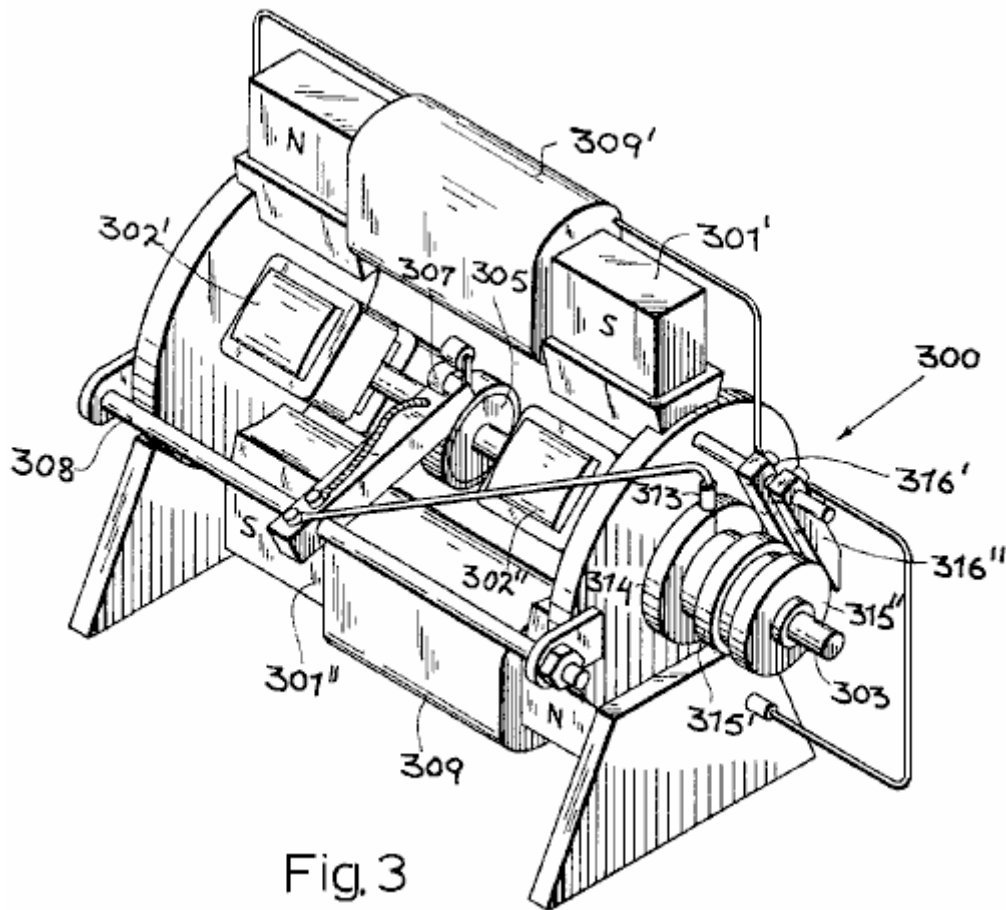

Fig. 3

**Fig.3** shows a generator **300** which is basically similar to the generator **100** shown in **Fig.1** and **Fig.1A**. It's shaft **303** carries a pair of laminated soft-iron armatures **302'**, **302''** which can rotate in the air gaps of a pair of electromagnets **301'**, **301''** which have windings **309'** and **309''**. The commutator **305** again co-operates with a pair of brushes **307**, only one of which is visible in **Fig.3**. This brush, carried on an arm **308**, is electrically connected to a brush **313** which engages with a slip-ring **314** positioned on an extremity of shaft **303** which also carries two further slip-rings **315'**, **315''** which are in conductive contact with ring **314** but are insulated from the shaft. Two further brushes **316'**, **316''** contact the rings **315'**, **315''** and respectively are connected to windings **309'** and **309''**. The other ends of these windings are connected to an analogous system of brushes and slip-rings on the extremity of the opposite shaft, and arranged so that the two commutator brushes are effectively bridged across the windings **309'** and **309''** in parallel. Therefore, in this embodiment, the stator magnets are energised from the generator output itself, it being understood that the magnets **301'** and **301''** (made, for example, of steel rather than soft iron) will have a residual coercive force sufficient to induce an initial output voltage. Naturally, the circuits leading from the brushes **307** to the windings **309'**, **309''** may include filtering as described in connection with **Fig.4**.

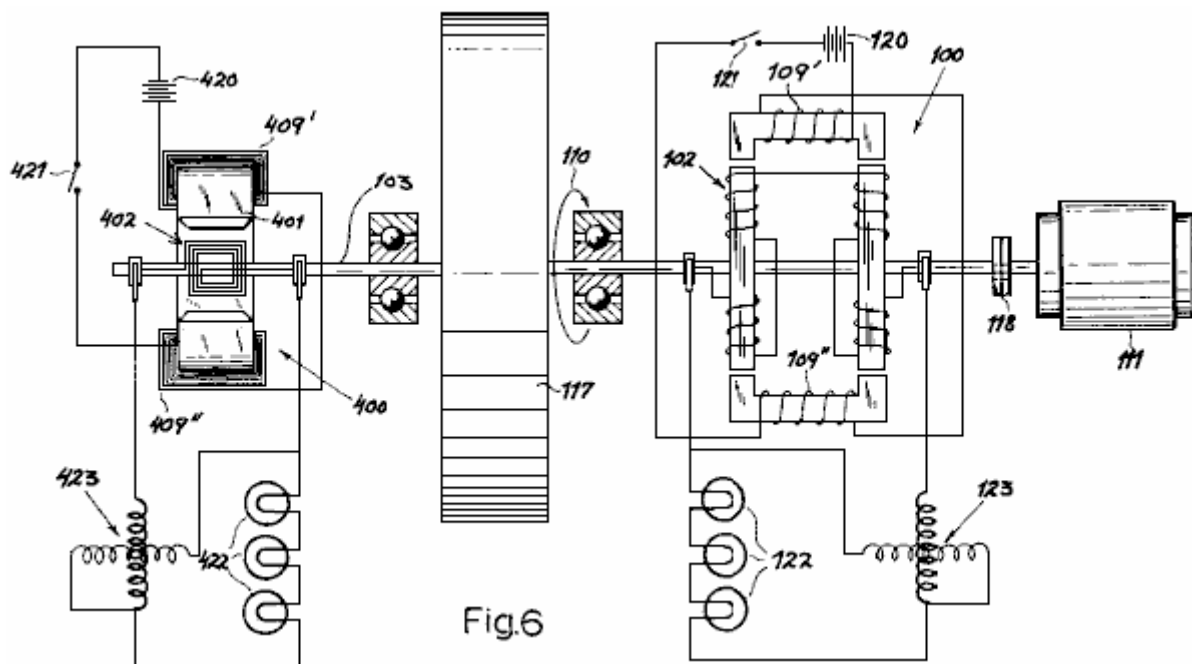

Fig.6

**Fig.6** shows a test circuit designed to compare the outputs of a generator of this design, such as the unit **100** of **Fig.1** and **Fig.1A**, with a conventional generator **400** of the type having a looped armature **402** which rotates in the gap of a stator magnet **401** which is fitted with energising windings **409'**, **409''**. The two generators are interconnected by a common shaft **103** which carries a flywheel **117**. This shaft is coupled through a clutch **118** to a drive motor **111** which drives the rotors **402** and **102** of both generators in unison, as indicated by arrow **110**. Two batteries **120** and **420**, in series with switches **121** and **421**, represent the method of supplying direct current to the stator windings **109'**, **109''** and **409'**, **409''** of the two generators.

The rectified output of generator **100** is delivered to a load **122**, shown here as three incandescent lamps connected in series, and with a combined consumption of 500 watts. Generator **400**, provides current into an identical load **422**. Two wattmeters **123** and **423** have their voltage and current windings connected respectively in shunt and in series with their associated loads **122** and **422**, to measure the electric power delivered by each generator.

When clutch **118** is engaged, shaft **113** with it's flywheel **117** is brought to an initial driving speed of 1,200 rpm. at which point, the switch **421** in the energising circuit of the conventional generator **400**, is closed. The lamps **422** light immediately and the corresponding wattmeter **423** shows an initial output of 500 watts. However, this output drops immediately as the flywheel **117** is decelerated by the braking effect of the magnetic field on armature **402**.

Next, the procedure is repeated but with switch **421** open and switch **121** closed. This energises generator **100** and the lamps **122** light up, wattmeter **123** showing an output of 500 watts, which remains constant for an indefinite period of time, there being no appreciable deceleration of flywheel **117**. When the clutch **118** is released and the rotor speed gradually decreases, the output of generator **100** is still substantially 500 watts at a speed of 900 rpm. and remains as high as 360 watts when the speed dropped further to 600 rpm. In a similar test with a generator of the permanent magnet type, such as the one shown at **200** in **Fig.2**, a substantially constant output was observed over a range of 1600 to 640 rpm.

**Teruo Kawai.** In July 1995, a patent was granted to Teruo Kawai for an electric motor. In the patent, Teruo states that a measured electrical input 19.55 watts produced an output of 62.16 watts, and that is a COP of 3.18. The main sections of that patent are included in the Appendix.

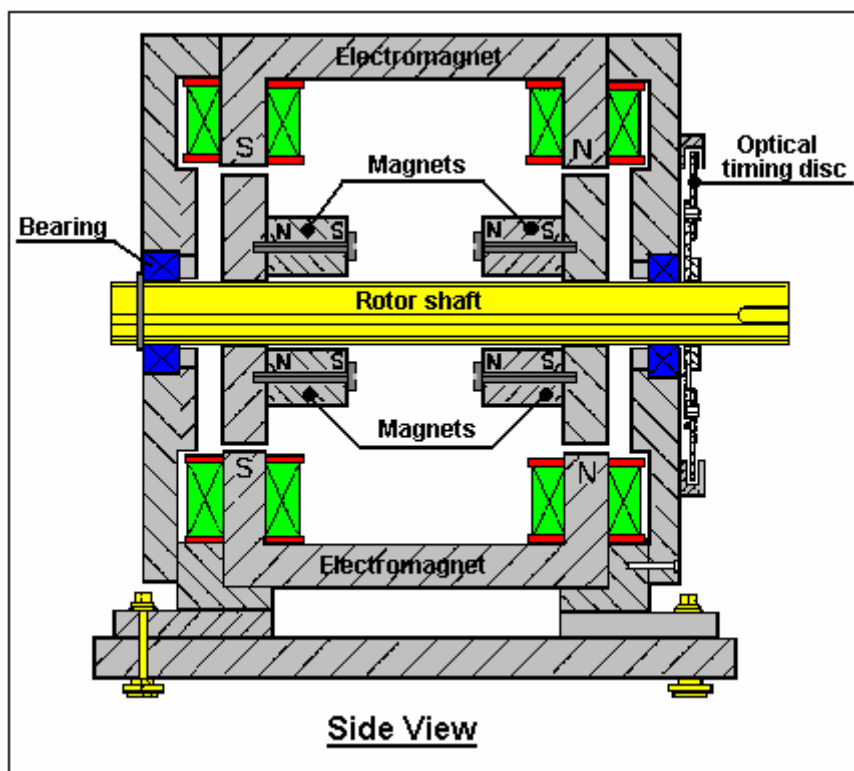
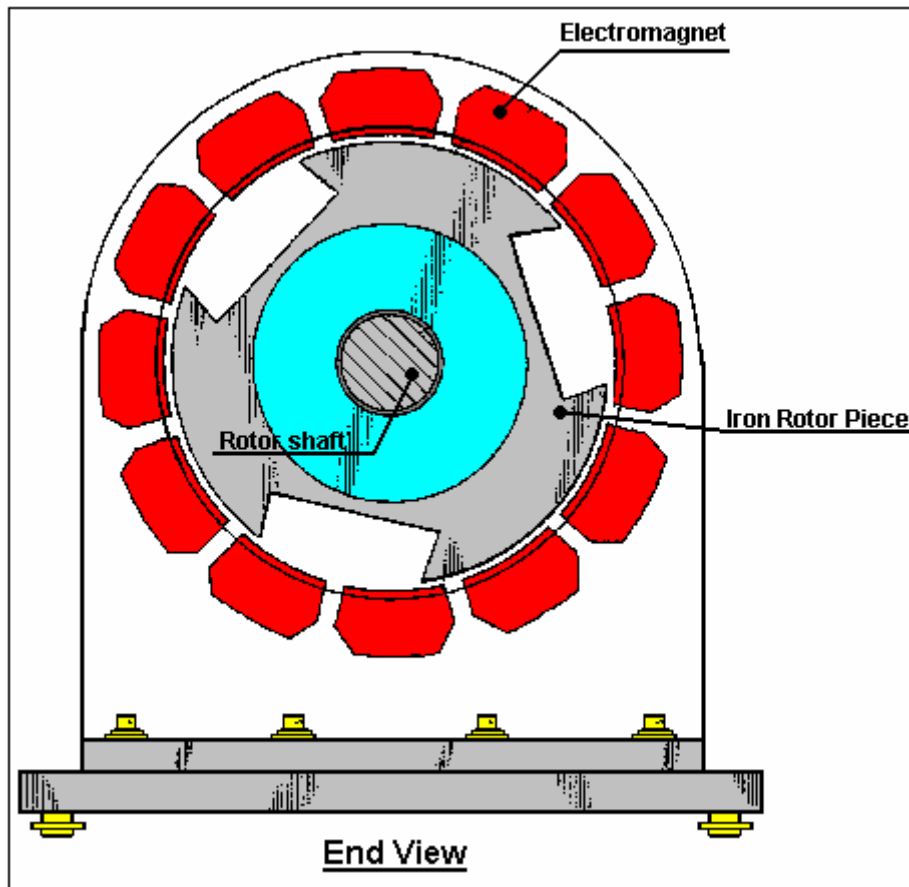

In this motor, a series of electromagnets are placed in a ring to form the active stator. The rotor shaft has two iron discs mounted on it. These discs have permanent magnets bolted to them and they have wide slots cut in them to alter their magnetic effect. The electromagnets are pulsed with the pulsing controlled via an optical disc arrangement mounted on the shaft. The result is a very efficient electric motor whose output has been measured as being in excess of its input.

**Self-Powered Water-pump Generator.** There is a video on Google which shows a self-powered electrical water-pump driven, electrical generator at the location: [http://video.google.com.au/videoplay?docid=-3577926064917175403&ei=b1\\_BSO7UDILAigKA4oCuCQ&q=self-powered+generator&vt=lf](http://video.google.com.au/videoplay?docid=-3577926064917175403&ei=b1_BSO7UDILAigKA4oCuCQ&q=self-powered+generator&vt=lf)

This is a very simple device where the jet of water from the pump is directed at a simple water-wheel which in turn, spins an electrical alternator, powering both the pump and an electric light bulb, demonstrating free-energy.



Initially, the generator is got up to speed, driven by the mains electrical supply. Then, when it is running normally, the mains connection is removed and the motor/generator sustains itself and is also able to power at least one light bulb. The generator output is normal mains current from a standard off-the-shelf alternator.





**The Muller Motor.** Bill Muller who died in 2004, produced a series of very finely engineered devices, the latest of which he stated produced some 400 amps of output current at 170V DC for 20 amps at 2V DC drive current. The device both generates its own driving power and produces an electrical power output. Bill's device weighed some 90 kilos and it requires very strong magnets made of Neodymium-Iron-Boron which are expensive and can easily cause serious injury if not handled with considerable care. It should be noted that Ron Classen shows the details of his work in replicating this motor on his web site <http://home.mchsi.com/~act2/index.html> and he reports that he spent in excess of US \$3,000 in construction and so far, has already achieved an output power of about 170% of the input power. A video of his motor in action is at <http://video.google.com/videoplay?docid=65862828639099378> and his development is progressing steadily. Ronald points out that decreasing the gap between the rotor and the stator by just one millimetre raises the input and output current by ten amps, so the potential of his machine is ten times greater than its present performance. Ronald has not implemented this as yet since the cost of the switching components is fairly high. His construction looks like this:

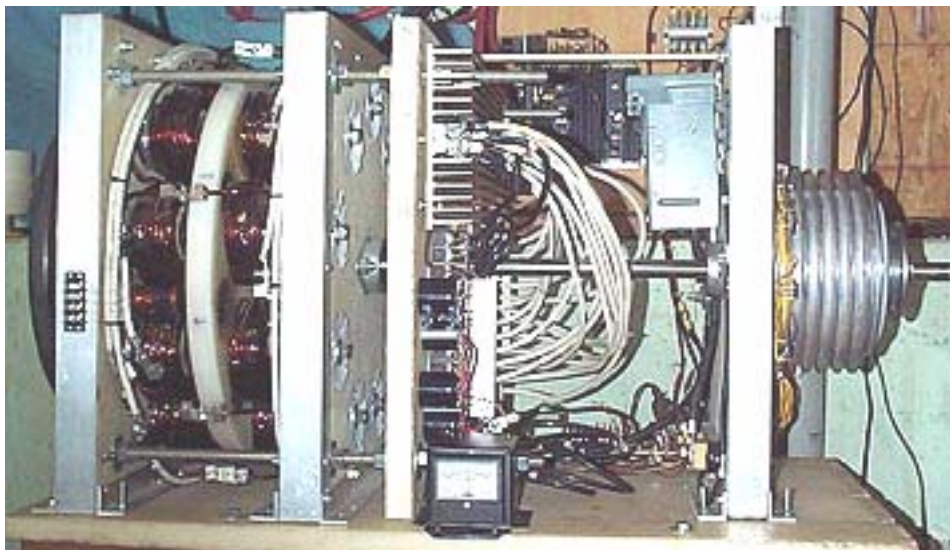

The Muller motor has a lot in common with Robert Adam's pulsed permanent-magnet motor. Both use a rotor which contains permanent magnets. Both pulse electromagnets at the precise moment to achieve maximum rotor torque. Both have pick-up coils for generating an electrical output. There are, however, considerable differences. Bill Muller's coils are wound in an unusual way as shown below. He positions his rotor magnets off-centre in relation to the stator coils. His coils are operated in pairs which are wired in series - one each side of the rotor. He has an odd number of coils and an even number of permanent magnets. His magnets are positioned with alternate polarity: N, S, N, S, ...

In order to make it easier to follow, the diagrams below show just five coil pairs and six magnets, but much larger numbers are normally used in an actual construction of the device, typically sixteen magnets.



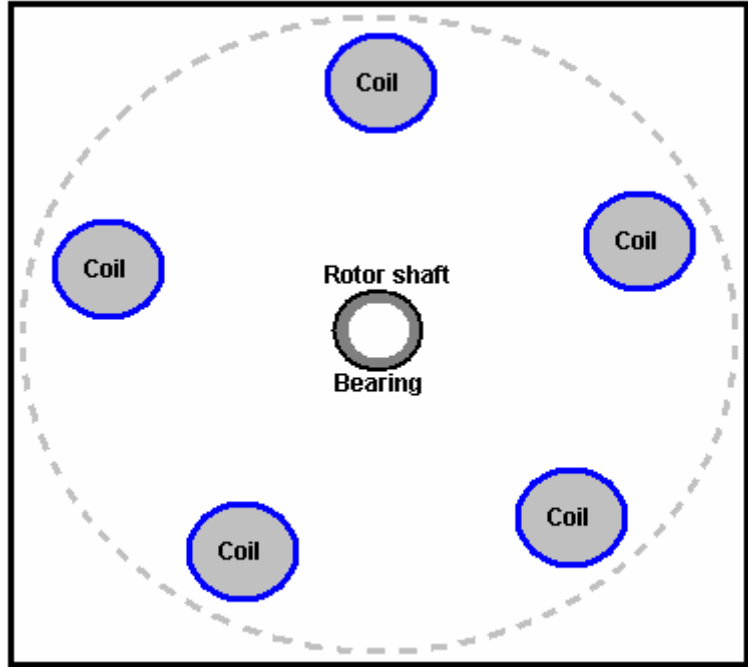

**Stator (2 required)**

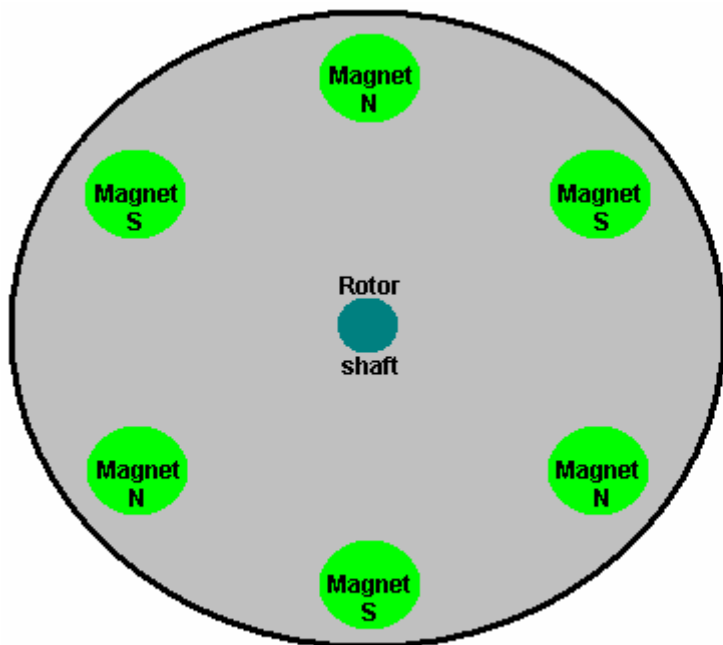

**Rotor (1 required)**

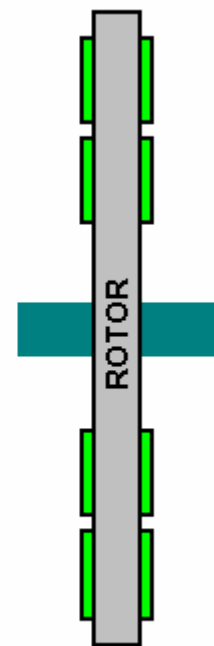

**Side view**

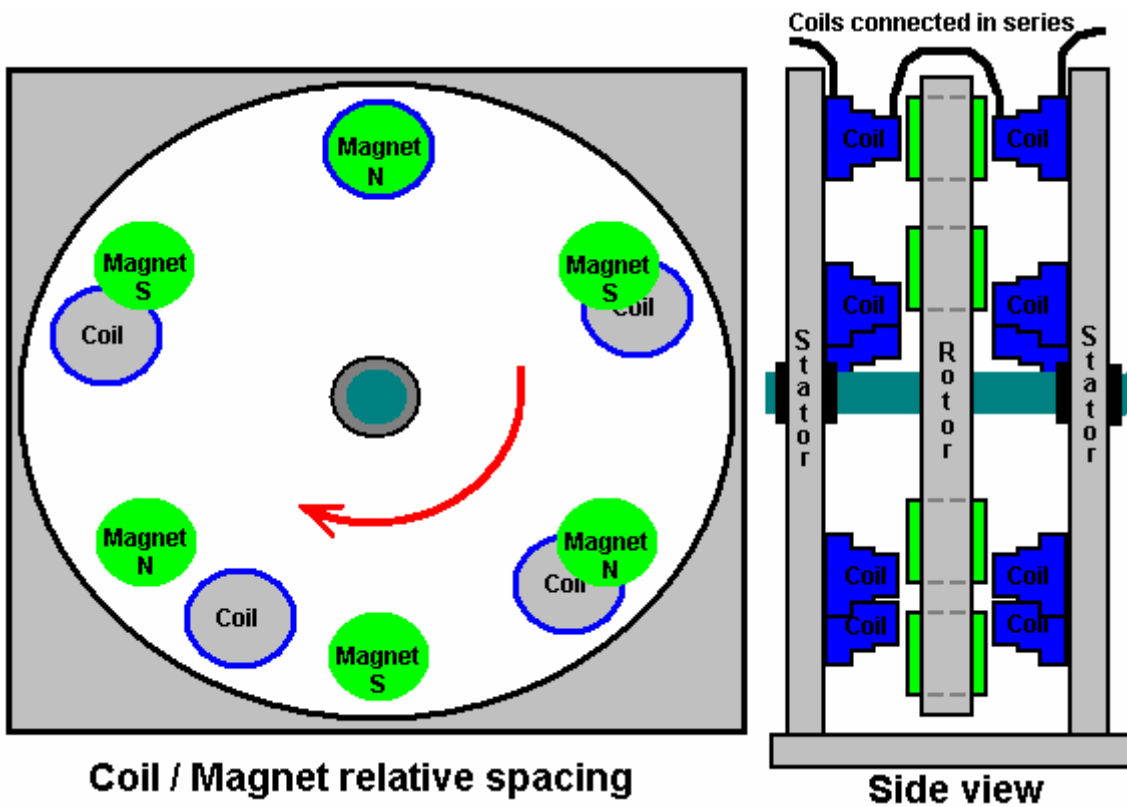

If AC mains voltage is used then the drive wiring may be as shown here:

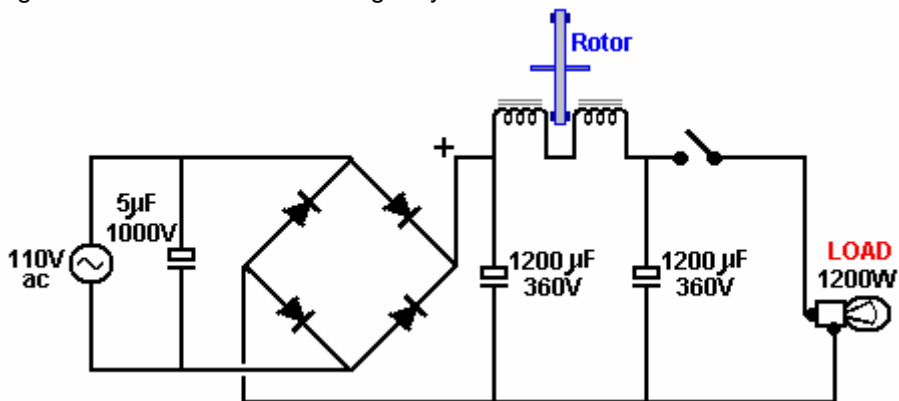

When adapted for five pairs of coils, this becomes:

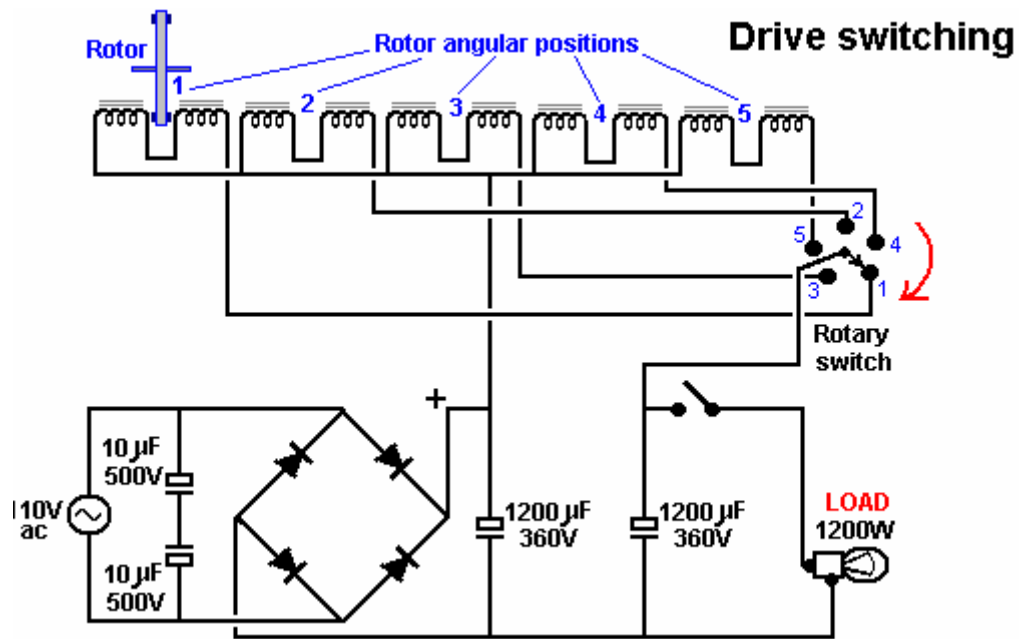

If DC switching is used, then the circuit may be:

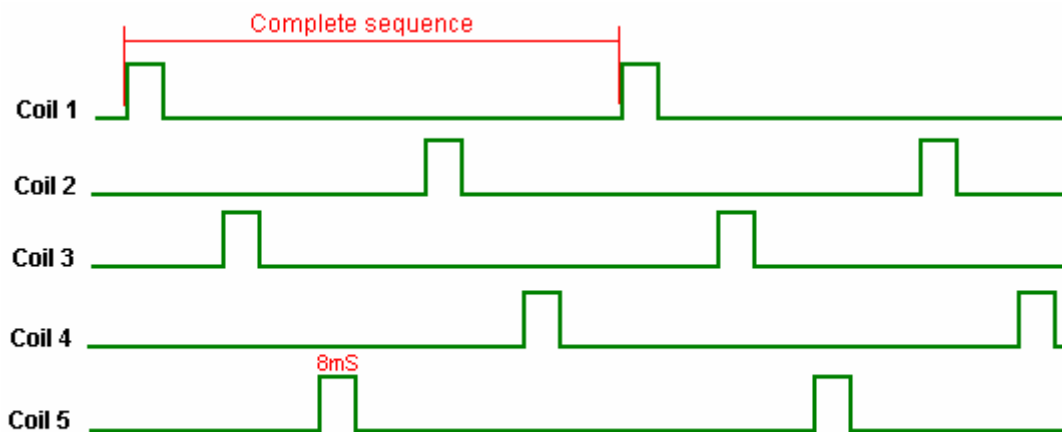
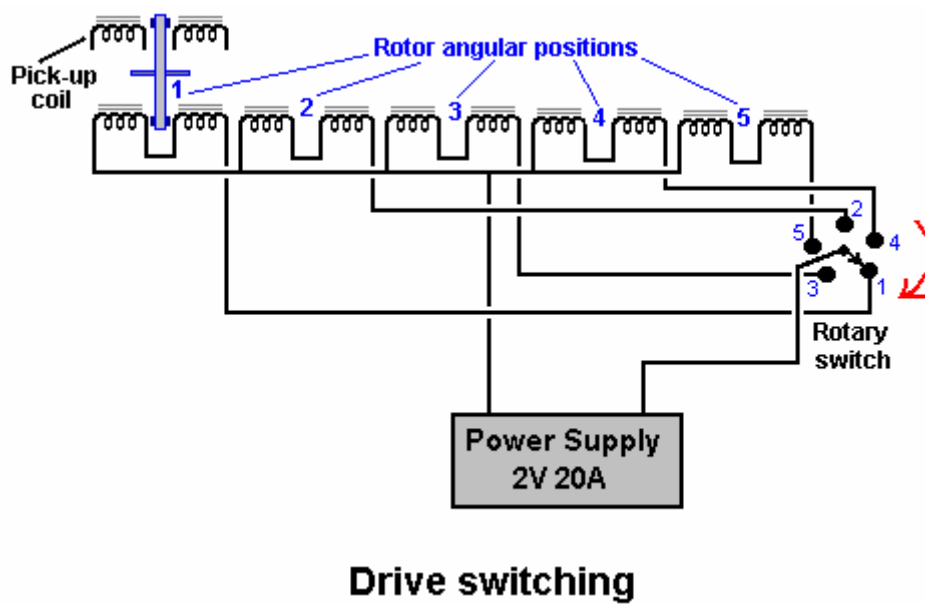

This is an unusual arrangement made all the more peculiar by the fact that the drive pulsing is carried out on the same coils which are used for power generation. The driving power pulse is applied to every successive coil which, with just five coils, makes the drive sequence 1, 3, 5, 2, 4, 1, 3, 5, 2, 4 .... For this operation, Coil 1 is disconnected from the power generation circuitry and then given a short high-power DC pulse. This boosts the rotation of the rotor. Coil 1 is then re-connected to the power generating circuitry, and coil 3 is disconnected and then given a drive pulse. This is repeated for every second coil, indefinitely, which is one of the reasons why there is an odd number of coils. The following table shows how the drive is operated.

Pulse:	1	2	3	4	5	6	7	8	9	10
Coil 1	<b>Pulse</b>	Power	Power	Power	Power	<b>Pulse</b>	Power	Power	Power	Power
Coil 2	Power	Power	Power	<b>Pulse</b>	Power	Power	Power	Power	<b>Pulse</b>	Power
Coil 3	Power	<b>Pulse</b>	Power	Power	Power	Power	<b>Pulse</b>	Power	Power	Power
Coil 4	Power	Power	Power	Power	<b>Pulse</b>	Power	Power	Power	Power	<b>Pulse</b>
Coil 5	Power	Power	<b>Pulse</b>	Power	Power	Power	Power	<b>Pulse</b>	Power	Power

It is essential that Neodymium-Iron-Boron magnets are used for this device as they are about ten times more powerful than the more common ferrite types. Bill used sixteen magnets in the 30 - 50 MegaGaussOersted energy density range, constructed in China, they held their magnetism unaltered for eight years of use. The air gap between the coils and the magnets is 2 mm. Bill used a computer chip to generate the switching sequence, and Ronald Classen who is expert in these systems points out that the pulsing system is adjusted when the motor speed increases. This change is not a simple one as when the speed of rotation reaches its maximum level, on a sixteen magnet rotor, only three of the magnets would be driven by coils pulses. That is, during one rotation, just three electromagnets would be energised in one simultaneous pulse, and that pulse would be of longer duration than the pulses which accelerated to rotor from its stationary position.

The output from each coil is passed through a full-wave bridge to give DC, before being added to the output from the other coils. A typical Muller motor would have 16 magnets and 15 coil pairs. The solid coil formers were made from 'amorphous metal' and are 2 inches (50 mm) in diameter and 3 inches (75 mm) long. Bill used a special mix of 'black sand' (probably magnetite granules) encased in epoxy resin, but an alternative is said to be hard steel - the harder the better. The coil core material is said to be very important and his construction was said to be free of any hysteresis eddy currents. The coils are wound from #6 AWG (SWG 8) or #8 AWG (SWG 10) wire and are formed in an unusual fashion as shown here:

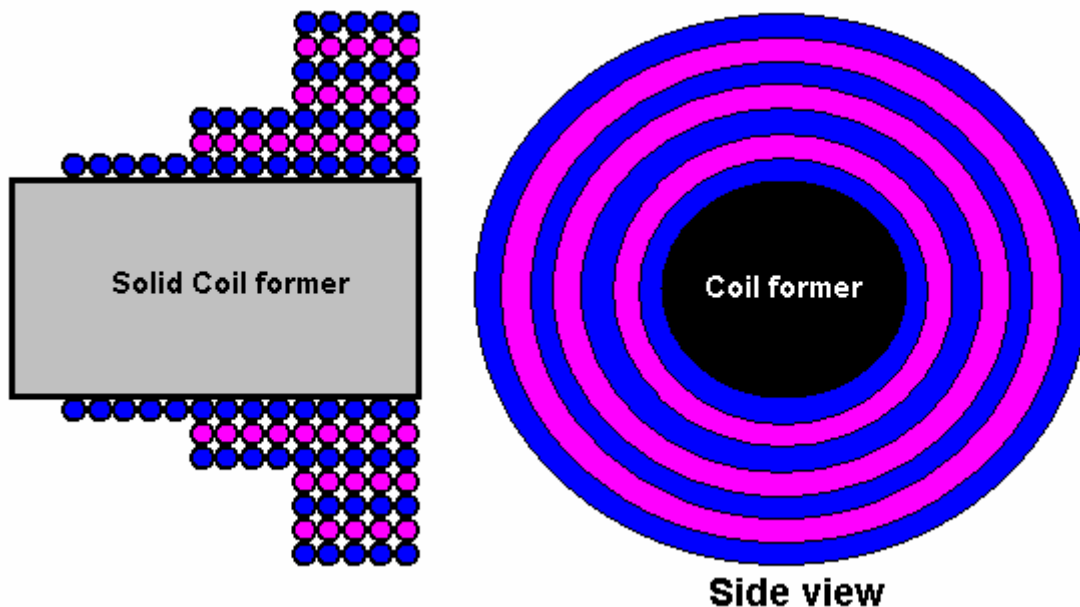

The winding turns are all made in the same direction. The first layer has 14 turns, the next two layers have 9 turns each, and the remaining four layers have 5 turns each, which gives a total of 52 turns. The coils are used in pairs, being wired in series, with one of each pair being on the opposite side of the rotor to the second coil of the pair, as indicated on the drawings. The way in which the coils are connected to the stator

is not certain. The thin end of the coils face the rotor magnets. The pick-up coils are not shown on the drawings, but they are placed on both of the stators, in every position where there is no drive coil.

The rotor is constructed of non-magnetic material and spins at about 3,000 rpm. This device has the potential to output 35 kW of excess power when constructed in the size described, which has a rotor diameter of 660 mm with the magnets centred on a circle of 570 mm. In the demonstration which produced 35 kW of power, only five out of the intended thirty pairs of pick-up coils had been constructed. It is predicted that the output would be 400 horsepower if all thirty pairs of pick-up coils were in place. Predictions of this nature need to be borne out in a demonstration before they can be considered valid. Please be aware of the size of this item of equipment. I personally, would not be able to pick up a device of this weight, but would need mechanical lifting equipment to move it. It can, of course, be constructed in a scaled down size which will have a scaled down electrical output.

Let me stress that handling magnets of this strength has its dangers. Should you take a magnet in your hand and inadvertently move your hand near a loose steel item, then your hand is liable to become trapped between the magnet and the steel object. This may result in serious damage to your hand. Great care should be taken.

The official web site for this system is [www.mullerpower.com](http://www.mullerpower.com) which you may find difficult to display unless you have the MacroMedia software installed on your computer. An alternative information site on the constructional details is <http://www.theverylastpageoftheinternet.com/menu/muller.htm> which shows both motor details and details of a separate 'over-unity' experiment which lights four 300W light bulbs while taking 1100W directly from the AC mains supply.

**The RotoVerter.** Not all pulsed-drive systems use permanent magnets as part of their drive mechanism. For example, the RotoVerter, designed by Hector D Peres Torres of Puerto Rico, and which has been reproduced by several independent researchers, producing at least 10 times more output power than the input power, uses standard three-phase electric motors instead of magnets.

This system has been reproduced by several independent researchers and it produces a substantial power gain when driving devices which need an electrical motor to operate. At this time, the web site: [www.theverylastpageoftheinternet.com/ElectromagneticDev/arkresearch/rotoverter.htm](http://www.theverylastpageoftheinternet.com/ElectromagneticDev/arkresearch/rotoverter.htm) has details on how to construct the device. The outline details are as follows:

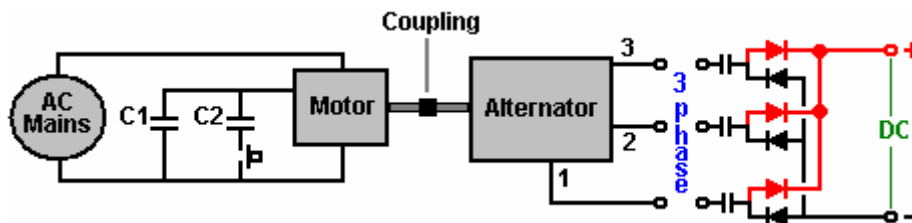

The output device is an alternator which is driven by a three-phase mains-powered, 3 HP to 7.5 HP motor (both of these devices can be standard 'asynchronous squirrel-cage' motors). The drive motor is operated in a highly non-standard manner. It is a 240V motor with six windings as shown below. These windings are connected in series to make an arrangement which should require 480 volts to drive it, but instead, it is fed with 120 volts of single-phase AC. The input voltage for the motor, should always be a quarter of its rated operational voltage. A virtual third phase is created by using a capacitor which creates a 90-degree phase-shift between the applied voltage and the current.

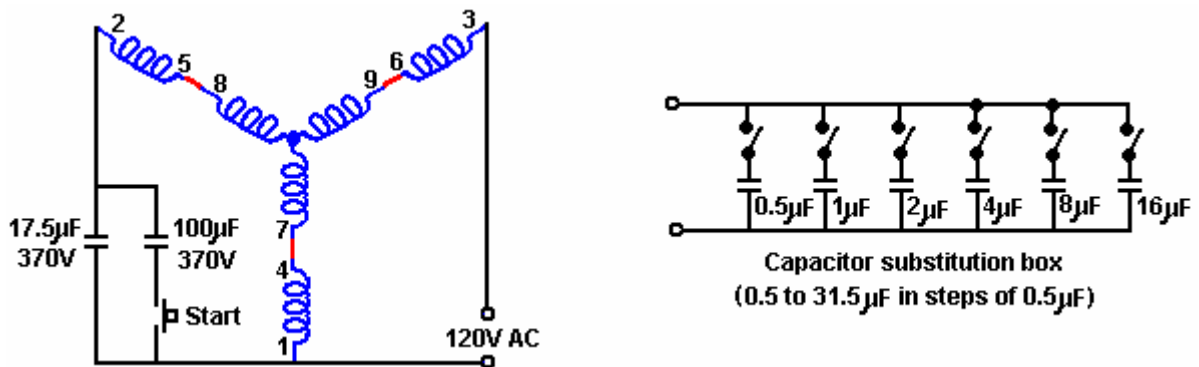

The objective is to tune the motor windings to give resonant operation. A start-up capacitor is connected into the circuit using the press-button switch shown, to get the motor up to speed, at which point the switch is released, allowing the motor to run with a much smaller capacitor in place. Although the running capacitor is shown as a fixed value, in practice, that capacitor needs to be adjusted while the motor is running, to give resonant operation. For this, a bank of capacitors is usually constructed, each capacitor having its own ON/OFF switch, so that different combinations of switch closures give a wide range of different overall values of capacitance. With the six capacitors shown above, any value from 0.5 microfarad to 31.5 microfarad can be rapidly switched to find the correct resonant value. These values allow combined values of 0.5, 1.0, 1.5, 2.0, 2.5, 3.0, 3.5, .....by selecting the appropriate switches to be ON or OFF. Should you need a value greater than this, then wire a 32 microfarad capacitor in place and connect the substitution box across it to test higher values step by step to find the optimum value of capacitor to use. The capacitors need to be powerful, oil-filled units with a high voltage rating - in other words, large, heavy and expensive. The power being handled in one of these systems is large and setting one up is not without a certain degree of physical danger. These systems have been set to be self-powered but this is not recommended, presumably because of the possibility of runaway with the output power building up rapidly and boosting the input power until the motor burns out.

The Yahoo EVGRAY Group at <http://groups.yahoo.com/group/EVGRAY> has a large number of members many of whom are very willing to offer advice and assistance. A unique jargon has built up on this forum, where the motor is not called a motor but is referred to as a "Prime Mover" or "PM" for short, which can cause confusion as "PM" usually stands for "Permanent Magnet". RotoVerter is abbreviated to "RV" while "DCPMRV" stands for "Direct Current Permanent Magnet RotoVerter" and "trafo" is a non-standard abbreviation for "transformer". Some of the postings in this Group may be difficult to understand due to their highly technical nature and the extensive use of abbreviations, but help is always available there.

To move to some more practical construction details for this system. The motor (and alternator) considered to be the best for this application is the "Baldor EM3770T" 7.5 horsepower unit. The specification number is 07H002X790, and it is a 230/460 volts 60Hz 3-phase, 19/9.5 amp, 1770 rpm, power factor 81, device.

The Baldor web site is [www.baldor.com](http://www.baldor.com) and the following details should be considered carefully before trying any adaption of an expensive motor. The following constructional photographs are presented here by kind permission of Ashweth of the EVGRAY Group.

The end plate of the drive motor needs to be removed and the rotor lifted out. Considerable care is needed when doing this as the rotor is heavy and it must **not** be dragged across the stator windings as doing that would damage them.



The second end-plate is then removed and placed on the opposite end of the stator housing:



The fan is removed as it is not needed and just causes unnecessary drag, and the rotor is inserted the opposite way round to the way it was removed. That is, the housing is now the other way round relative to the rotor, since the rotor has been turned through 180 degrees before being replaced. The same part of the shaft of the rotor passes through the same end plate as before as the end plates have also been swapped over. The end plates are bolted in position and the rotor shaft spun to confirm that it still rotates as freely as before.

To reduce friction to an absolute minimum, the motor bearings need to be cleaned to an exceptional level. There are various ways of doing this. One of the best is to use a carburettor cleaner spray from your local car accessories shop. Spray inside the bearings to wash out all of the packed grease. The spray evaporates if left for a few minutes. Repeat this until the shaft spins perfectly, then put one (and only one) drop of light oil on each bearing and do not use WD40 as it leaves a residue film. The result should be a shaft which spins absolutely perfectly.

The next step is to connect the windings of the two units. The motor (the "Prime Mover") is wired for 480 volt operation. This is done by connecting winding terminals 4 to 7, 5 to 8 and 6 to 9 as shown below. The diagram shows 120 volts AC as being the power supply. This is because the RotoVerter design makes the motor operate at a much lower input than the motor designers intended. If this motor were operated in the standard way, a 480 volt 3-phase supply would be connected to terminals 1, 2 and 3 and there would be no capacitors in the circuit.



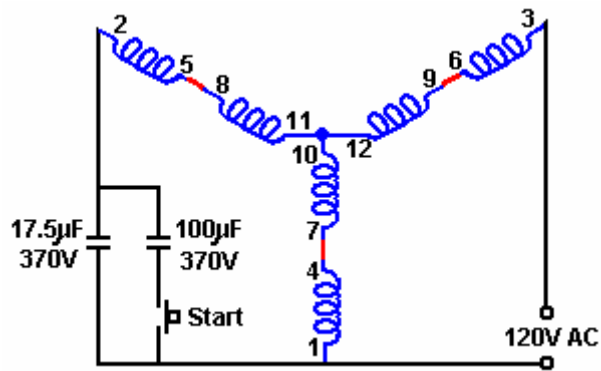

It is suggested that the jumpering of the motor windings is more neatly done by removing the junction box cover and drilling through it to carry the connections outside to external connectors, jumpered neatly to show clearly how the connections have been made for each unit, and to allow easy alterations should it be decided to change the jumpering for any reason.

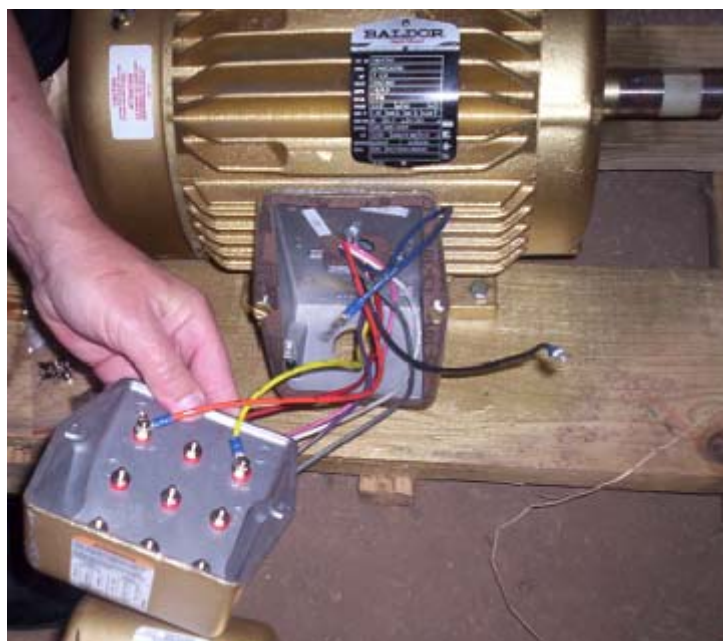

The same is done for the unit which is to be used as the alternator. To increase the allowable current draw, the unit windings are connected to give the lower voltage with the windings connected in parallel as shown below with terminals 4,5 and 6 strapped together, 1 connected to 7, 2 connected to 8 and 3 connected to 9.



This gives a three-phase output on terminals 1, 2 and 3. This can be used as a 3-phase AC output or as three single-phase AC outputs, or as a DC output by wiring it as shown here:

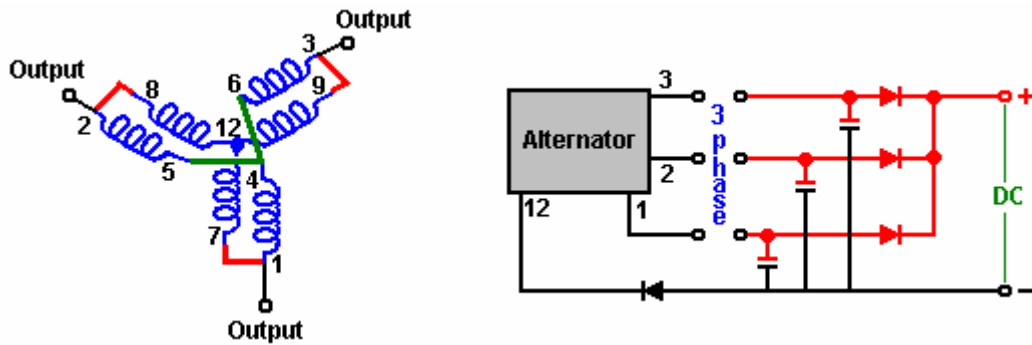

The motor and the alternator are then mounted securely in exact alignment and coupled together. The switching of the direction of the housing on the drive motor allows all of the jumpering to be on the same side of the two units when they are coupled together, facing each other:



The input drive may be from an inverter driven from a battery charged via a solar panel. The system now needs to be 'tuned' and tested. This involves finding the best 'starting' capacitor which will be switched into the circuit for a few seconds at start-up, and the best 'running' capacitor.

To summarise: This device takes a low-power 110 Volt AC input and produces a much higher-power electrical output which can be used for powering much greater loads than the input could power. The output power is much higher than the input power. This is free-energy under whatever name you like to apply to it. One advantage which should be stressed, is that very little in the way of construction is needed, and off-the-shelf motors are used. Also, no knowledge of electronics is needed, which makes this one of the easiest to construct free-energy devices available at the present time. One slight disadvantage is that the tuning of the "Prime Mover" motor depends on its loading and most loads have different levels of power requirement from time to time. A 220 Volt AC motor can also be used if that is the local supply voltage.

It is not essential to construct the RotoVerter exactly as shown above, although that is the most common form of construction. The Muller Motor mentioned earlier, can have a 35 kilowatt output when precision-constructed as Bill Muller did. One option therefore, is to use one Baldor motor jumpered as the "Prime Mover" drive motor and have it drive one or more Muller Motor style rotors to generate the output power:

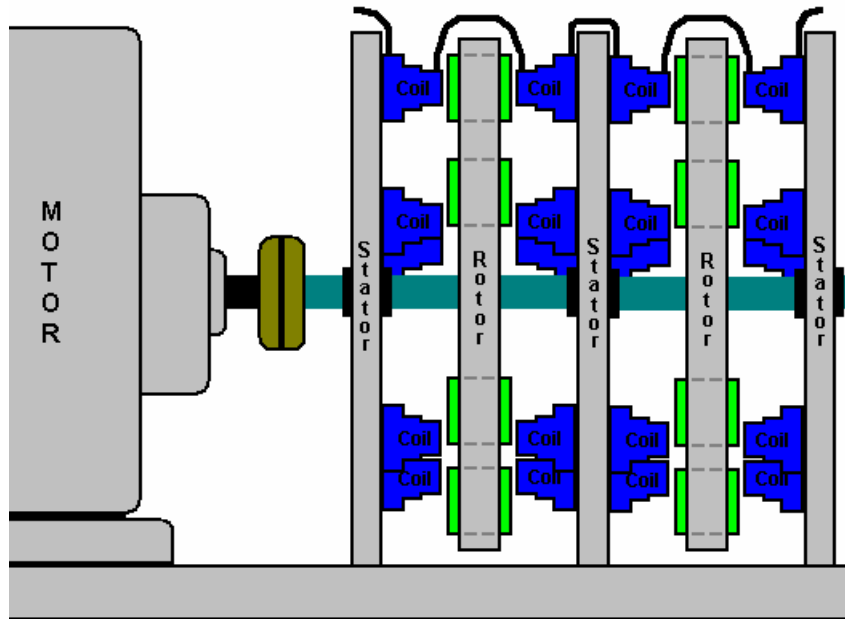

Generally, the RotoVerter gives very low input power when not loaded and about a 90% energy reduction when under load. The ideal situation is where there is a constant load as the tuning of the RotoVerter does depend to some degree on the load. However, the RotoVerter performance can be increased very substantially by using the techniques introduced by **Raoul Hatem** in 1955, which conventional science will not accept because according to current theory, any such energy gain has to be “impossible” and so, cannot happen no matter what evidence there is (<http://quanthomme.free.fr/qhsuite/hatemCUdu%20brevet.htm>):



**Raoul Hatem's** heretical statement is that using spinning magnets draws in energy from the environment, allowing a system to have  $COP > 1$  (ever heard of John Searle's spinning magnet systems?). His method is

to use a motor (whether RotoVerter or not) to spin a heavy rotor disc with 36 powerful rare-earth magnets mounted on it. Then, using an identical heavy disc with magnets mounted on a generator to give a magnetic coupling between the motor and the generator can give not just coupling, but an energy gain as well:

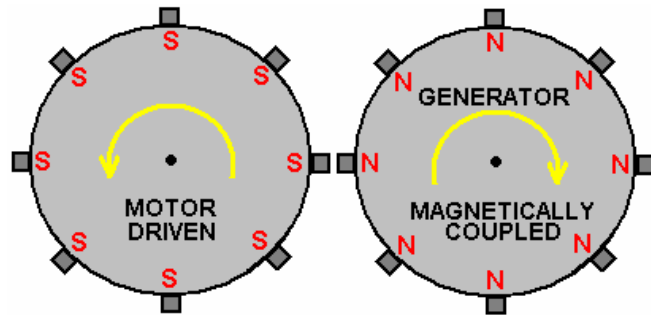

The heavy rotor provides some flywheel effect which helps with the operation of the system. Even with one motor as shown above, there is an energy gain as demonstrated in a recent video demonstration of the effect at <http://www.youtube.com/watch?v=V-MQvzOCNSI> where a simple system produces 144 watts of excess power. However, the really big gains are got when several generators are driven by just the one motor. In passing, it may be remarked that there are two separate energy gain systems operating here. Firstly, the rotating magnetic field acts directly on the excess electrons in the local environment, drawing them into the system just as the fluctuating magnetic field of the secondary winding of any transformer does. Secondly, the rotors are receiving a rapid stream of drive pulses, and as Chas Campbell has demonstrated, that draws in excess energy from the gravitational field.

Anyway, you will notice that the powerful magnets used have their North poles outwards on one rotor while the adjacent rotor has the South poles outwards. The very strong attraction between these opposite poles cause the generator disc to rotate in step with the motor disc. This process allows many generators to be driven by just the one motor as shown here and in the photograph above:

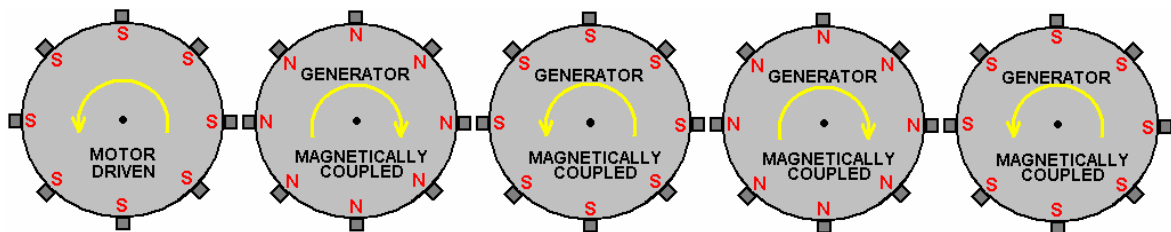

For ease of drawing, the diagram above shows only eight magnets per rotor disc, but you will notice in the photograph (and in the video) that there are three stepped rows of magnets on each rotor:

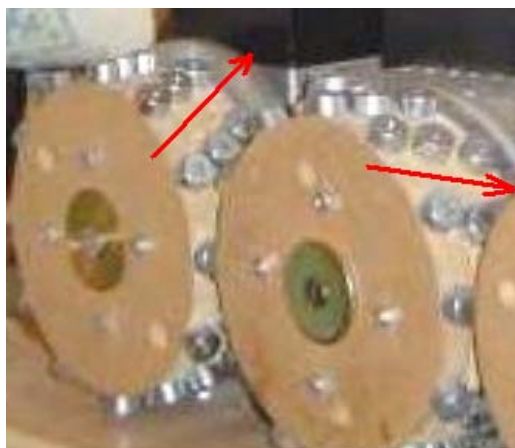

You will also notice that direction of the stepping is reversed on every second rotor disc in order for the magnets to match each other in position as they rotate in opposite directions.

While this type of arrangement gives a major increase in the output power compared to the input power, the situation can be further enhanced by retrieving some of the input power by means of electronic circuitry, and both Phil Wood and David Kousoulides have kindly shared their methods for doing this:

**Phil Wood**, has many years of experience working with all varieties of electric motor, has come up with a very clever circuit variation for the RotoVerter system. His design has a 240 volt Prime Mover motor driven with 240 volt AC. The revised circuit now has automated start-up and it provides an extra DC output which can be used to power additional equipment. His circuit is shown here:

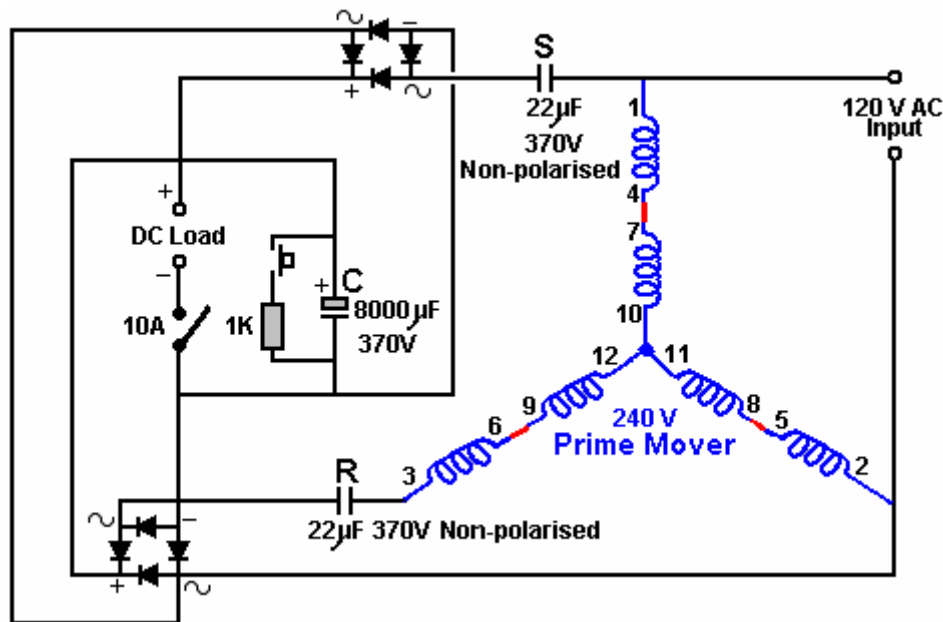

Phil specifies the diode bridges as 20 amp 400 volt and the output capacitor as 4000 to 8000 microfarads 370 volt working. The ON/OFF switch on the DC output should be 10 amp 250 volt AC working. The circuit operates as follows:

The charge capacitor "C" needs to be fully discharged before the motor is started, so the press-button switch is pressed to connect the 1K resistor across the capacitor to discharge it fully. If you prefer, the press-button switch and resistor can be omitted and the switch to the DC load closed before the AC input is applied. The switch must then be opened and the AC connected. The starting capacitor "S" and capacitor "R" both operate at full potential until capacitor "C" begins to charge. As capacitor "C" goes through its charging phase, the resistance to capacitors "R" and "S" increases and their potential capacitance becomes less, automatically following the capacitance curve required for proper AC motor operation at start-up.

After a few seconds of run time, the output switch is operated, connecting the DC load. By varying the resistance of the DC load, the correct tuning point can be found. At that point, the DC load resistance keeps both of the capacitors "R" and "S" operating at a potentially low capacitance value.

The operation of this circuit is unique, with all of the energy which is normally wasted when the AC motor is starting, being collected in the output capacitor "C". The other bonus is where a DC load is powered for free while it keeps capacitors "R" and "S" in their optimum operating state. The DC load resistance needs to be adjusted to find the value which allows automatic operation of the circuit. When that value has been found and made a permanent part of the installation, then the switch can be left on when the motor is started (which means that it can be omitted). If the switch is left on through the starting phase, capacitor "C" can be a lower value if the DC load resistance is high enough to allow the capacitor to go through its phase shift.

The capacitor values shown above were those found to work well with Phil's test motor which was a three-winding, 5 horsepower, 240 volt unit. Under test, driving a fan, the motor draws a maximum of 117 watts

and a variable speed 600 watt drill was used for the DC load. The motor operates at its full potential with this circuit.

-----

The circuit will need different capacitors for operation with a 120 Volt AC supply. The actual values are best determined by testing with the motor which is to be used, but the following diagram is a realistic starting point:

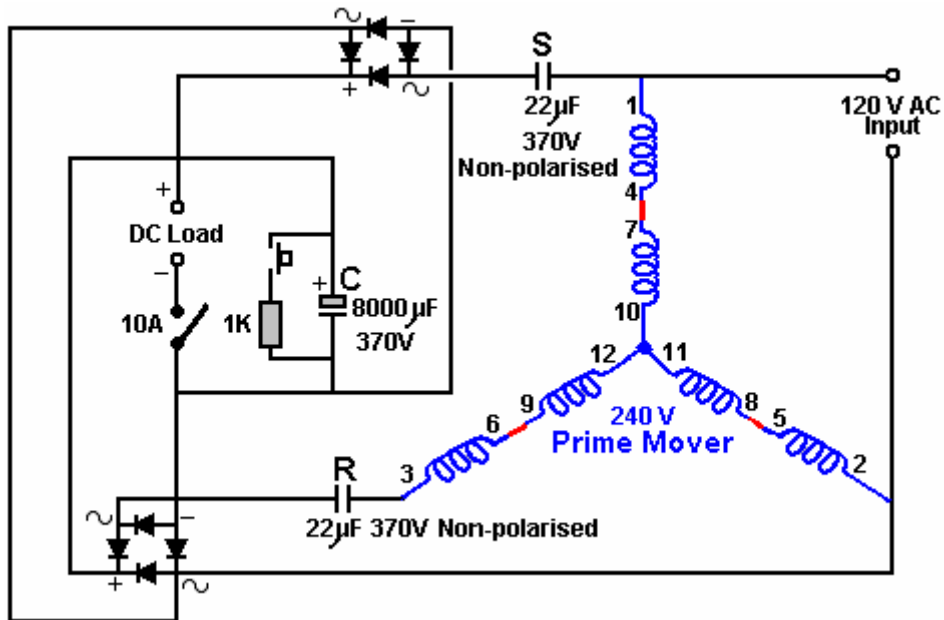

The 120 V AC motor runs very smoothly and quietly drawing only 20 watts of input power.

Advancing the design even further, Phil has now produced an extremely clever design by introducing an additional DC motor/generator coupled to the "Prime Mover" motor. The coupling is nominally mechanical with the two motors physically linked together with a belt and pulleys, but the electrical linking is such that the two motors will synchronise automatically if the mechanical linkage is omitted. I should like to express my thanks to him for sharing this information, diagrams and photographs freely.

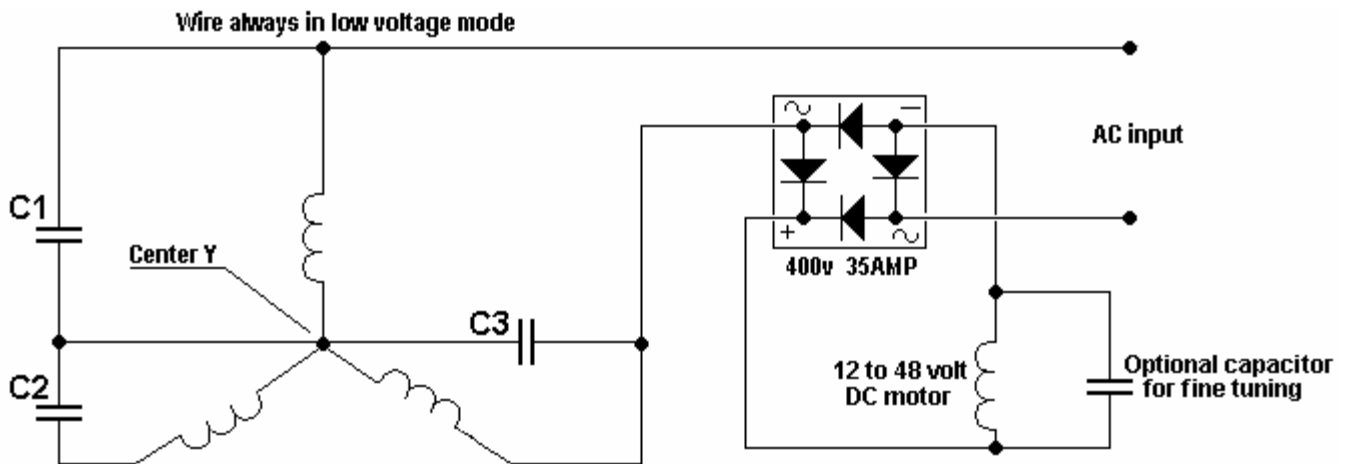

**C1, C2 and C3 are all the same value between 10 µF and 47µF 400 V**

**By Phil Wood**

This circuit is very clever as the DC motor/generator automatically adjusts the running of the AC motor both at start-up and under varying loading. Also, the selection of the capacitors is not so critical and no manual intervention is needed at start-up. In addition, the DC motor/generator can be used as an additional source of electricity.



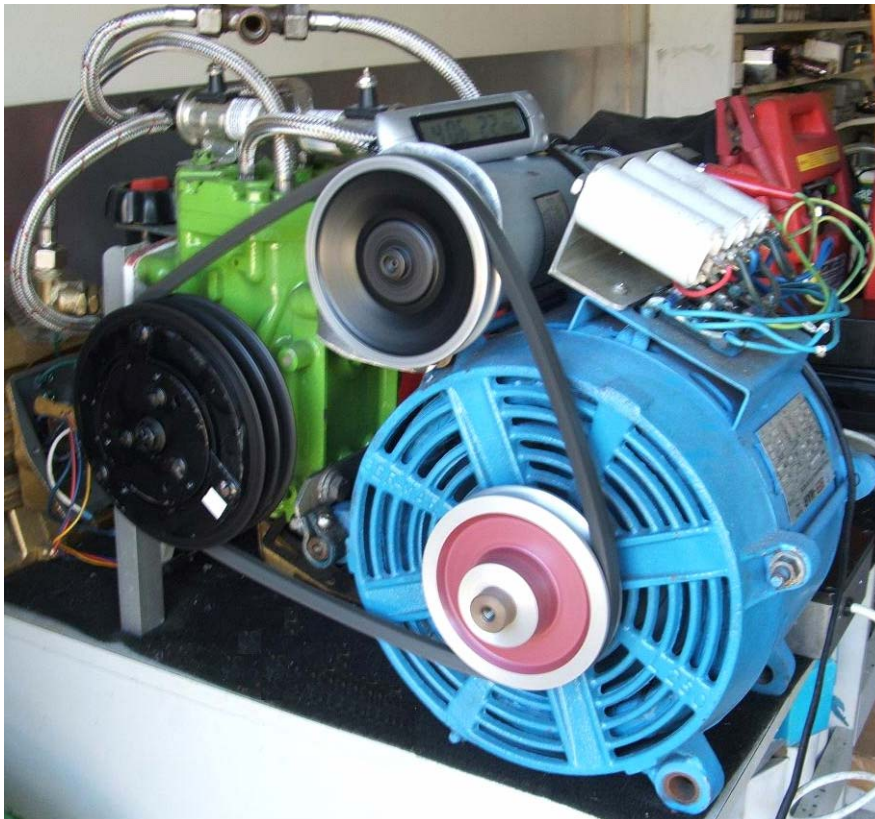
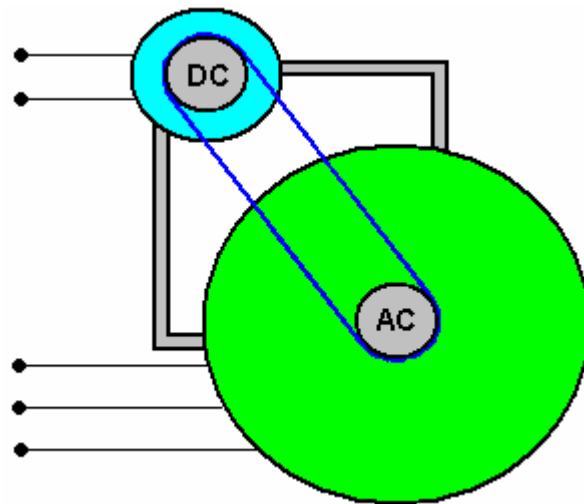

**Phil's setup**

As the loading on the Prime Mover motor is quite low due to the very, very high efficiency of the RotoVerter arrangement, it is perfectly feasible to drive the whole system with a low-power inverter run from a battery. If that is done, then it is possible to use two batteries. One is charged by the DC generator while the other is driving the inverter. A timer circuit then switches the batteries over on a regular basis using relay switching.

### **Extra Energy Collection**

A very effective additional circuit has been developed by David Kousoulides. This circuit allows extra current to be drawn off a RotoVerter while it is running, without increasing the input power needed to drive the RotoVerter. David's circuit can be used with a wide range of systems, but here it is being shown as an addition to the RotoVerter system, raising it's efficiency even higher than before.

As is common with many effective circuits, it is basically very simple looking, and it's apparent operation is easily explained. The objective is to draw additional current from the RotoVerter and use that current to

charge one or more batteries, without loading the RotoVerter at all. The current take off is in the form of a rapid series of current pulses which can be heard as a series of faint clicks when fed into the battery.

Let us examine the circuit section by section:

First, we start with a standard “off the shelf” 3-phase motor. In this example, the motor is a 7.5 horsepower motor, which when wired in RotoVerter mode, using just a single-phase supply as shown here, only draws a very low amount of power when running, especially if the single-phase supply is about 25% of the voltage rating of the motor:

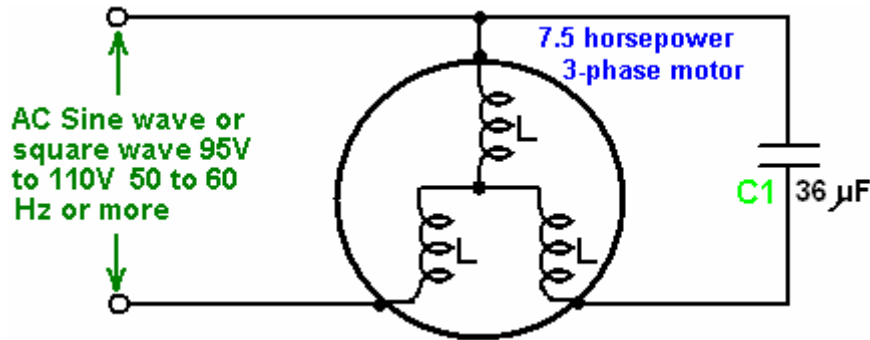

Because the running power draw is so low, it is possible to run this motor from a standard battery-powered inverter, but the current draw at start-up is some 17 amps, so the mains is used to get the motor started and then the motor is switched from the mains to the inverter. The inverter also allows easy measurement of the power input and so makes for easier calculation of the overall power efficiency of the system.

There is a power extraction device called a “diode-plug”, which in spite of it’s seeming simplicity, is actually much more subtle in it’s operation than would appear from a quick glance at the circuit:

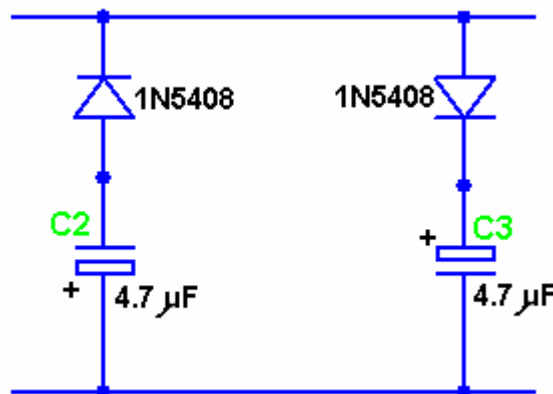

This circuit has been presented as a public-domain non-copyrightable circuit by Hector Perez Torres and it is capable of extracting power from a range of different systems, without affecting those systems or increasing their power draw. In the circuit presented below, just the first half of the diode plug is utilised, though it should perhaps be stressed that it would be perfectly feasible to raise the efficiency of the circuit even further by adding extra components to duplicate the power feed from the battery, drawing on both parts of the diode-plug circuit. For clarity, this is not shown here, but it should be understood that it is a possible, and indeed desirable, extension to the circuitry described here.

When the motor is running, high voltages are developed across the windings of the motor. As only the first half of the diode-plug is being shown here, we will be capturing and using the negative-going voltages. These negative-going pulses are picked up, stored in a capacitor and used to charge a battery using the following circuit:

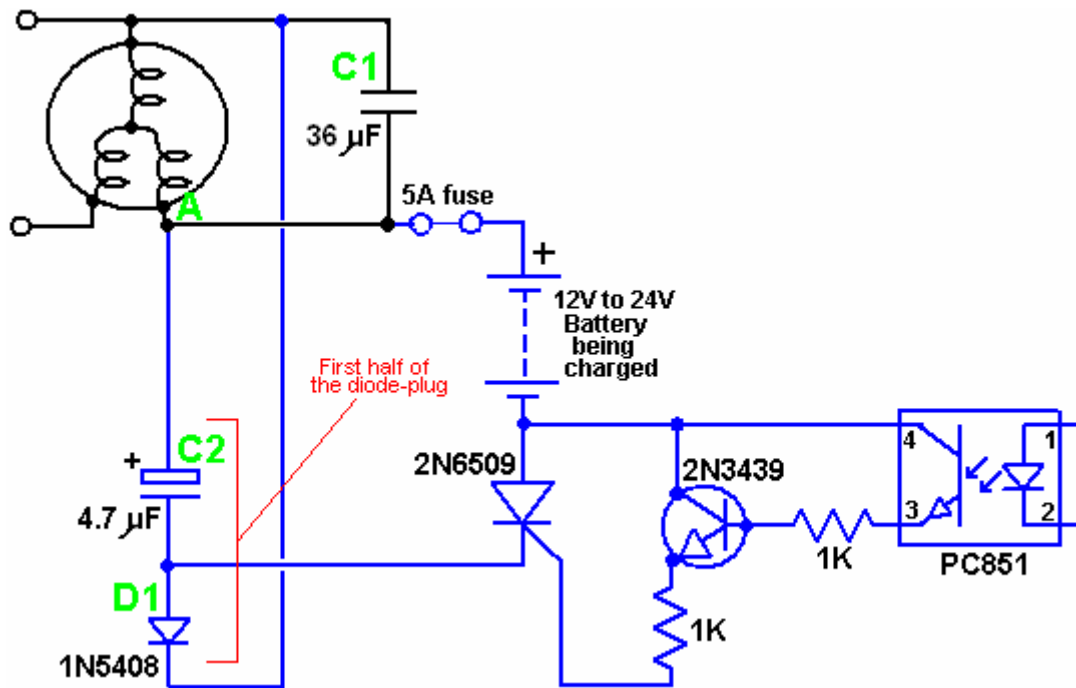

Here we have the same RotoVerter circuit as before, with high voltage being developed across capacitor C1. The battery-charging section is a free-floating circuit connected to point A of the motor. The high-voltage diode D1 is used to feed negative-going pulses to capacitor C2 which causes a large charge to build up in that capacitor. At the appropriate moment, the PC851 opto-isolator is triggered. This feeds a current into the base of the 2N3439 transistor, switching it on and firing the 2N6509 thyristor. This effectively switches capacitor C2 across the battery, which discharges the capacitor into the battery. This feeds a substantial charging power pulse into the battery. As the capacitor voltage drops, the thyristor is starved of current and it turns off automatically. The charging sequence for the capacitor starts again with the next pulse from the windings of the motor.

The only other thing to be arranged is the triggering of the opto-isolator. This should be done at the peak of a positive voltage on the motor windings and has been built like this:

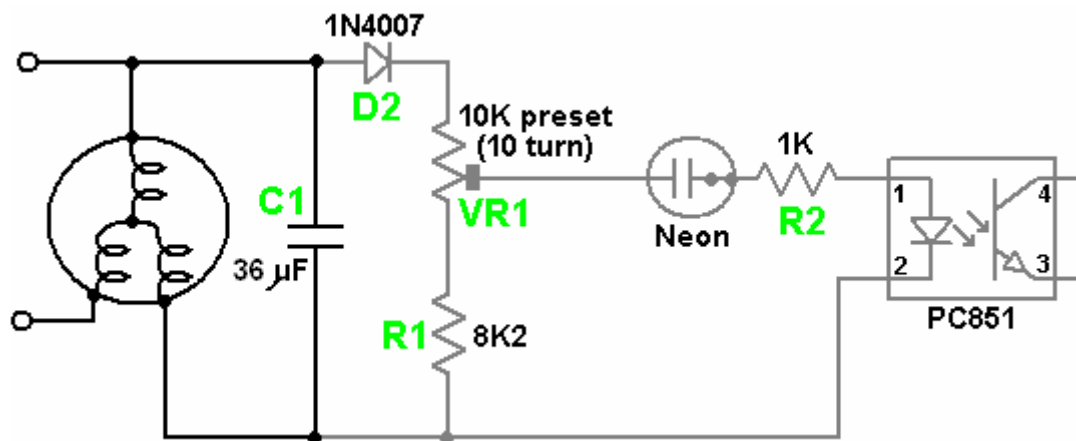

Here, we have the RotoVerter motor as before, with the voltage developed on C1 being used to trigger the opto-isolator at the appropriate moment. The voltage on C1 is sensed by the diode D2, the pre-set resistor VR1 and the resistor R1. These place a load of some 18.2K ohms on capacitor C1 as the neon has a very high resistance when not conducting. The ten-turn preset resistor is adjusted to make the neon fire at the peak of the voltage wave coming from the motor. Although the adjustment screw of most preset resistors is fully isolated from the resistor, it is recommended that adjustment of the screw be done using an insulated main-tester type of screwdriver, or a solid plastic trimmer-core adjustment tool.

The circuit to test one half of the diode plug is then:



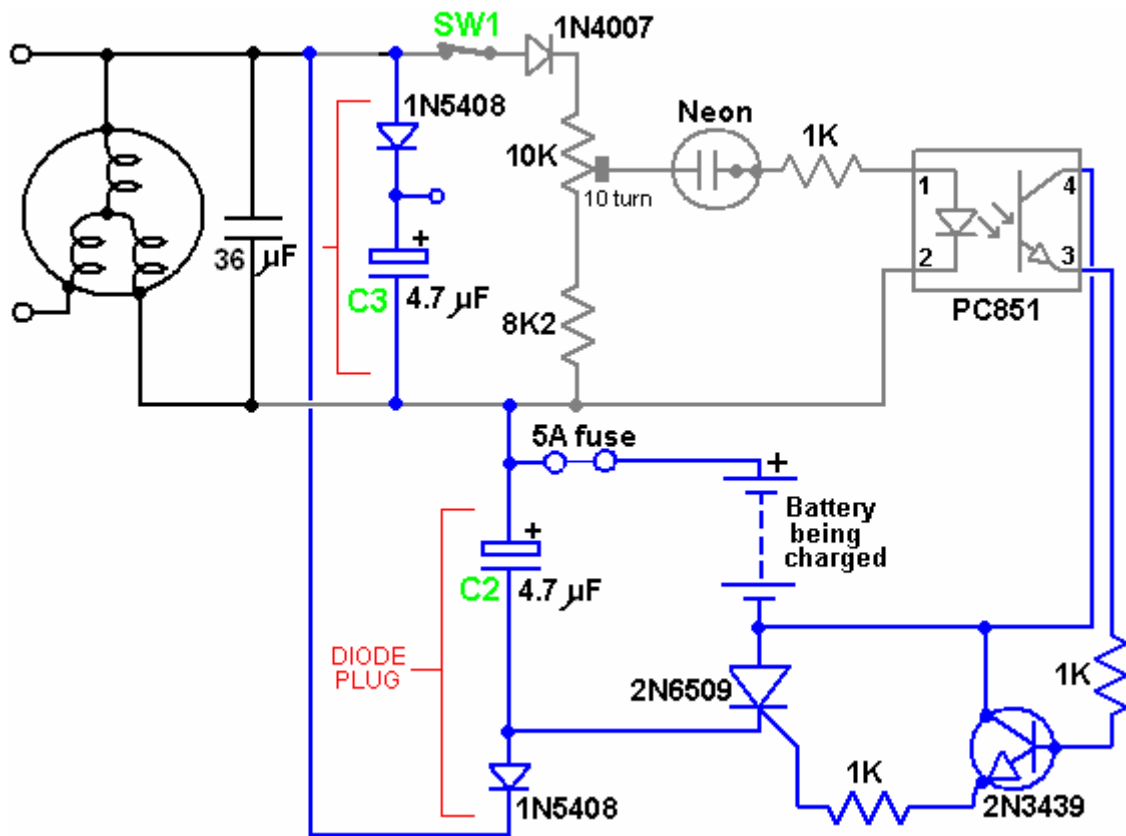

The switch SW1 is included so that the charging section can be switched off at any time and this switch should not be closed until the motor gets up to speed. All wire connections should be made before power is applied to the circuit. Capacitor C1 which is shown as 36 microfarads, has a value which is optimised for the particular motor being used and will normally be in the range 17 to 24 microfarads for a well-prepared motor. The motor used for this development was retrieved from a scrap yard and was not prepared in any way.

The value of capacitor C2 can be increased by experimenting to find at what value the resonance gets killed and the charging section starts drawing extra current from the supply. It should be noted that many new thyristors (Silicon Controlled Rectifiers or "SCRs) are faulty when supplied (sometimes as many as half of those supplied can be faulty). It is therefore important to test the thyristor to be used in this circuit before installing it. The circuit shown below can be used for the testing, but it should be stressed that even if the component passes the test, that does not guarantee that it will work reliably in the circuit. For example, while 2N6509 thyristors are generally satisfactory, it has been found that C126D types are not. A thyristor passing the test may still operate unpredictably with false triggers.

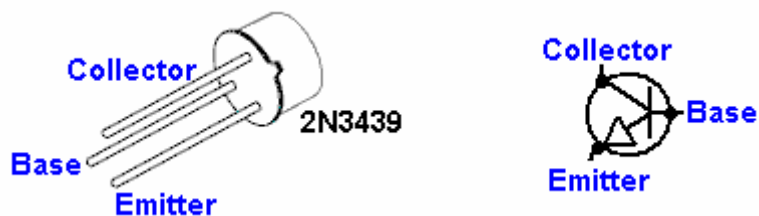

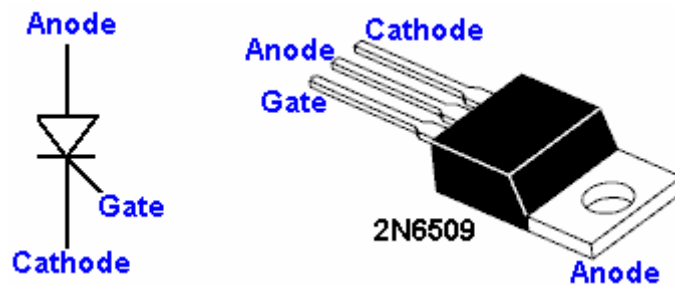
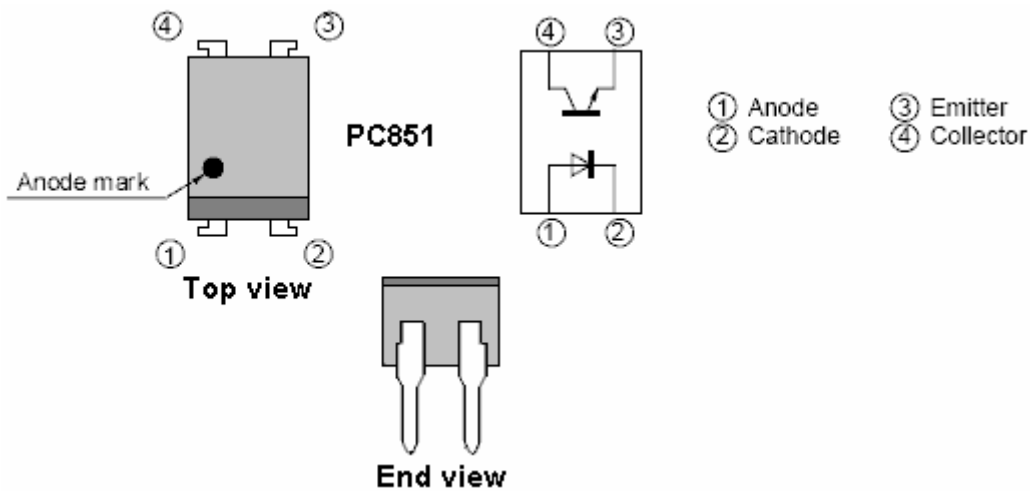

Please note that the 2N6509 package has the Anode connected inside the housing to the metal mounting tab.

Components List:

Component	Quantity	Description
1K ohm resistor 0.25 watt	3	Bands: Brown, Black, Red
8.2K ohm resistor 0.25 watt	1	Bands: Gray, Red, Red
10K ohm preset resistor	1	Ten turn version
4.7 mF 440V (or higher) capacitor	1	Polypropylene
36 mF 440V (or higher) capacitor	1	Non-polarised polypropylene
1N5408 diode	1	
1N4007 diode	1	
2N3439 NPN transistor	1	
2N6509 thyristor	1	Several may be needed to get a good one
PC851 opto-isolator	1	
Neon, 6 mm wire-ended, 0.5 mA	1	Radiospares 586-015
5A fuse and fuse holder	1	Any convenient type
30A switch 1-pole 1-throw	1	Toggle type, 120-volt rated
Veroboard or similar	1	Your preferred construction board
4-pin DIL IC socket	1	Black plastic opto-isolator holder (optional)
Wire terminals	4	Ideally two red and two black
Plastic box	1	Injection moulded with screw-down lid
Mounting nuts, bolts and pillars	8	Hardware for 8 insulated pillar mounts
Rubber or plastic feet	4	Any small adhesive feet
Sundry connecting wire	4 m	Various sizes

When using and testing this circuit, it is important that all wires are connected securely in place before the motor is started. This is because high voltages are generated and creating sparks when making connections does not do any of the components any particular good. If the circuit is to be turned off while the motor is still running, then switch SW1 is there for just that purpose.

The operating technique is as follows:

Before starting the motor, adjust the slider of the preset resistor VR1 to the fixed resistor end of its track. This ensures that the charging circuit will not operate as the neon will not fire. Power up the circuit and start adjusting the preset resistor very slowly until the neon starts to flash occasionally. There should be no increased load on the motor and so no extra current drawn from the input supply.

If there is an increase in the load, you will be able to tell by the speed of the motor and the sound it makes. If there is an increase in the load, then back off VR1 and check the circuit construction. If there is no increased load, then continue turning VR1 slowly until a position is reached where the neon remains lit all the time. You should see the voltage across the battery being charged increase without any loading effects on the motor.

If you use an oscilloscope on this circuit, please remember that there is no “ground” reference voltage and that the circuit is not isolated.

Here is a picture of David’s actual board construction. There are various ways for building any circuit. This particular construction method uses plain matrix board to hold the components in position and the bulk of the interconnections are made underneath the board. The charge-collecting capacitor is made here from two separate polypropylene 440 volt capacitors wired in parallel. David has opted to use a separate diode on each capacitor as this has the effect of doubling the current-carrying capacity of a single diode and is a popular technique in pulse charge circuits where sometimes several diodes are wired in parallel.

David has included a heatsink, which he marks as being “not required” but you will notice that there is insulation between the SCR and the heatsink. Mica “washers” available from the suppliers of semiconductors are particularly good for this, as mica is a good insulator and it also conducts heat very well.

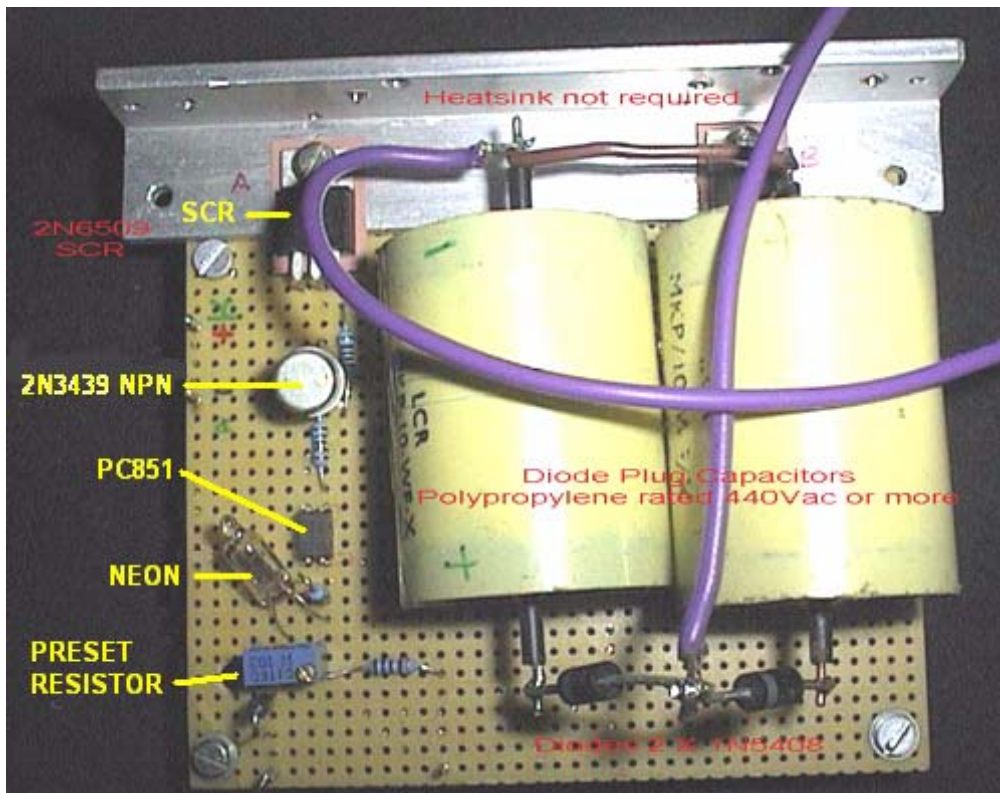

## Thyristor testing:

The components needed to construct the thyristor testing circuit shown below can be bought as Kit number 1087 from [www.QuasarElectronics.com](http://www.QuasarElectronics.com)

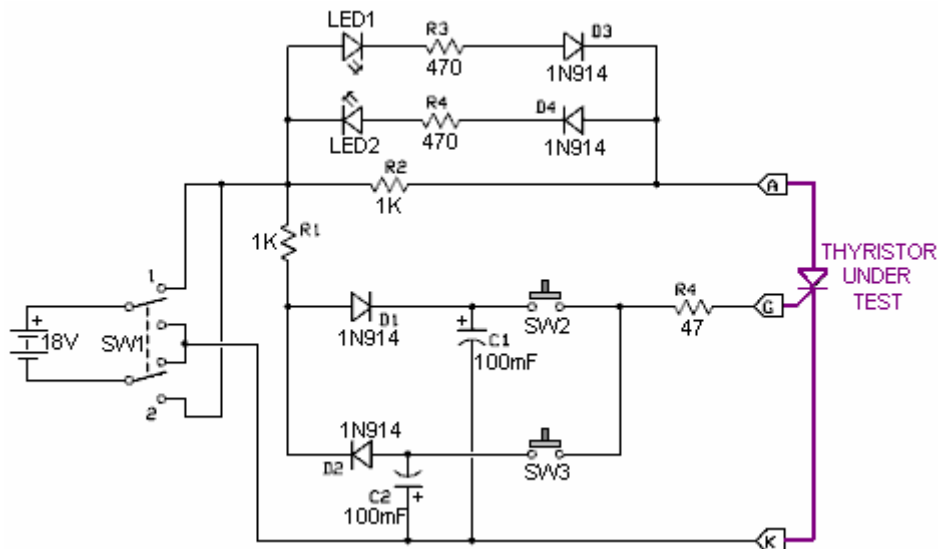

The circuit is operated by operating SW1 several times so as to get capacitors C1 and C2 fully charged. LED1 and LED2 should both be off. If either of them light, then the thyristor is faulty.

Next, with SW1 at its position 1, press switch SW2 briefly. LED1 should light and stay on after SW2 is released. If either of these two things does not happen, then the thyristor is faulty.

With LED1 lit, press SW3 and LED1 should go out. If that does not happen, then the thyristor is faulty.

As mentioned before, even if the thyristor passes these tests it does not guarantee that it will work correctly in any circuit as it may operate intermittently and it may trigger spuriously when it shouldn't.

## Component list:

Component	Quantity	Description
47 ohm resistor 0.25 watt	1	Bands: Purple, Yellow, Black
470 ohm resistor 0.25 watt	2	Bands: Purple, Yellow, Brown
1K ohm resistor	2	Bands: Brown, Black, Red
100 mF 15V capacitor	2	Electrolytic
1N914 diode	4	
Light Emitting Diode	2	Any type, any size
Toggle switch 2-pole 2-throw	1	
Press-button Push-to-Make	2	Non-latching press-on, release off type
9V battery	1	Any type
Battery connector	1	To match chosen battery
Socket	1	Plug-in socket for thyristors
Veroboard or similar	1	Your preferred construction board
Plastic box	1	Injection moulded with screw-down lid
Mounting nuts, bolts and pillars	8	Hardware for 8 insulated pillar mounts
Rubber or plastic feet	4	Any small adhesive feet
Sundry connecting wire	4 m	Various sizes

**Phil Wood** has developed a particularly effective method for extracting the excess resonant circulating energy of a RotoVerter Prime Mover. This is the circuit:

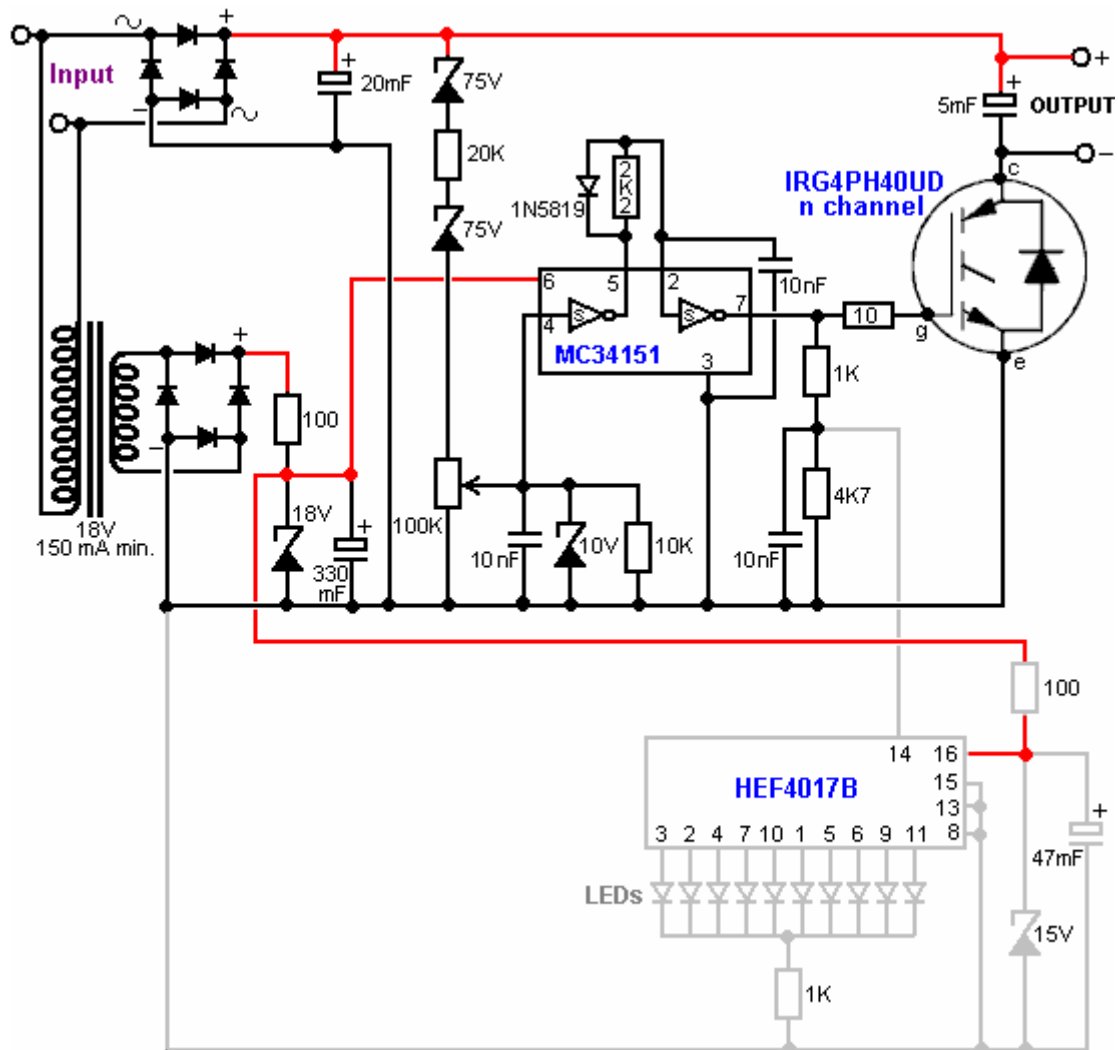

Care needs to be taken when constructing this circuit. For example, the circuit performance is displayed by an HEF4017B 5-stage Johnson counter, but for some lunatic reason, the 4017 designation is also used for a completely different chip of the same size and number of DIL pins, namely the “CMOS high-speed hex flip-flop with Reset”, an action definitely worthy of a stupidity award. Another point to watch out for is that the 1A 1N5819 diode is a very high-speed Schottky barrier component.

The circuit operation is as follows:

The input from the RotoVerter motor is stepped-down by a transformer to give an 18-volt (nominal) AC output, which is then rectified by a standard rectifier bridge and the output smoothed by an 18-volt zener diode and a 330mF smoothing capacitor, and used to power the MC34151 chip. This DC power supply line is further dropped and stabilised by a 15-volt zener diode and a 47mF capacitor and used to power the LED display chip HEF4017B.

The raw RotoVerter input is also taken direct and rectified by a second 400-volt 35-amp rectifier diode bridge and smoothed by a 20mF capacitor with a high voltage rating. It must be understood that the RotoVerter system is liable to produce considerable power surges from time to time and so this circuit must be capable of handling and benefiting from these surges. This is why the IRG4PH40UD IGBT device was selected (apart from it's very reasonable price) as it robust and can handle high voltages.

The resulting high-voltage DC is taken by the chain of components two 75-volt zener diodes, 20K resistor and the 100K variable resistor. The voltage developed on the slider of this variable resistor is loaded with a



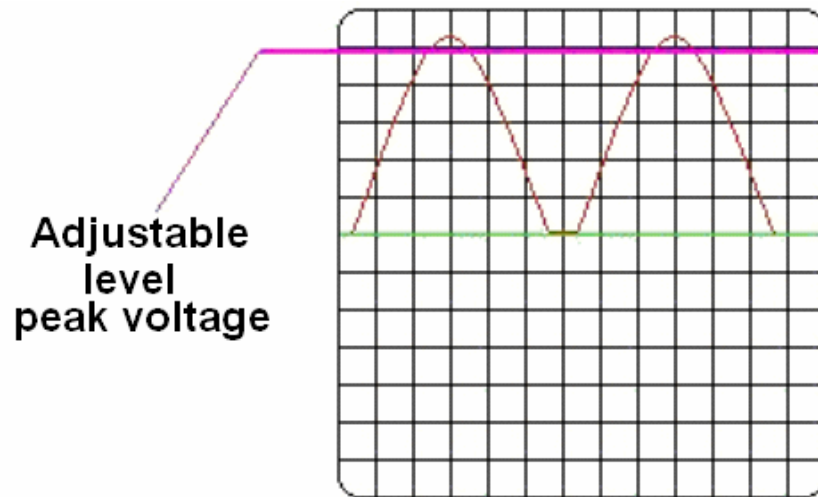

The pattern of the printed-circuit board when viewed from the underside of the board is shown here:

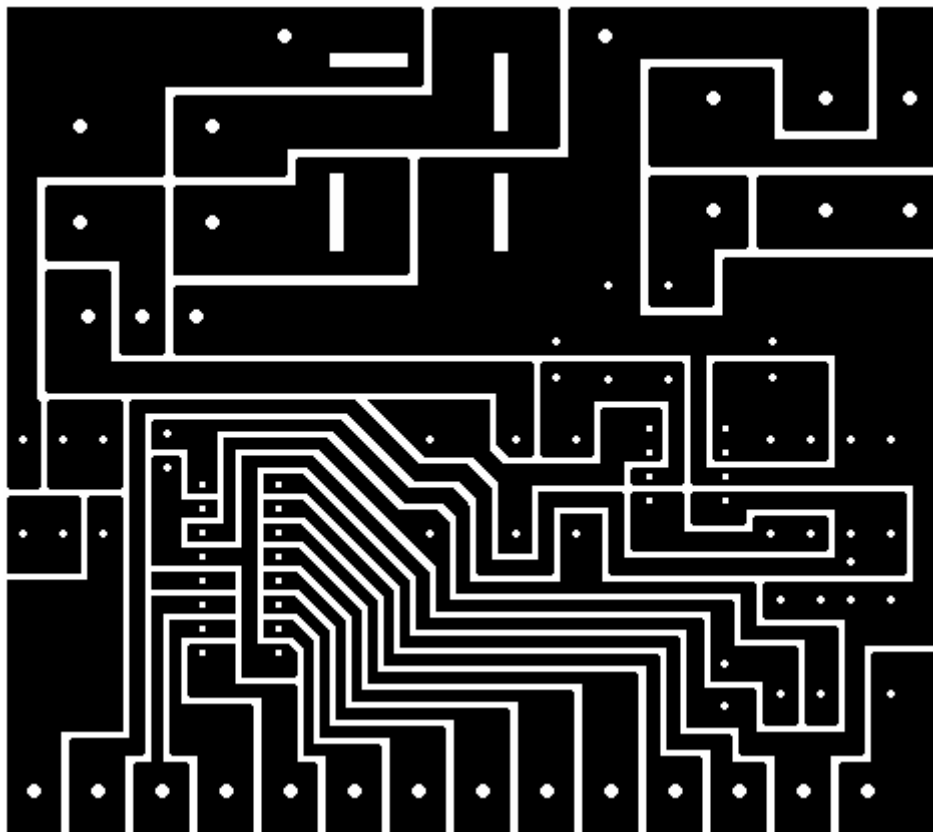

And component packaging is:



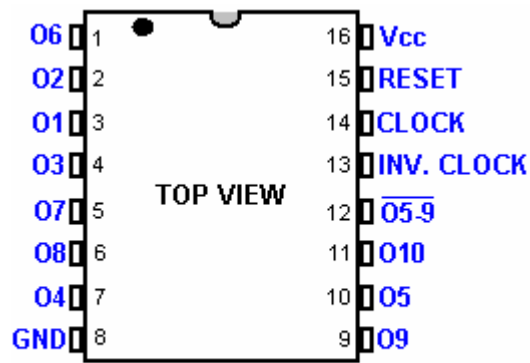

**HEF4017B**

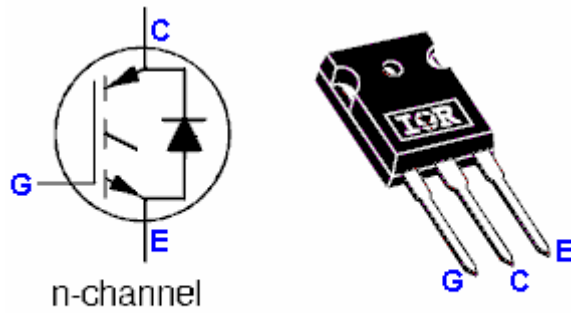

**IRG4PH40UD**

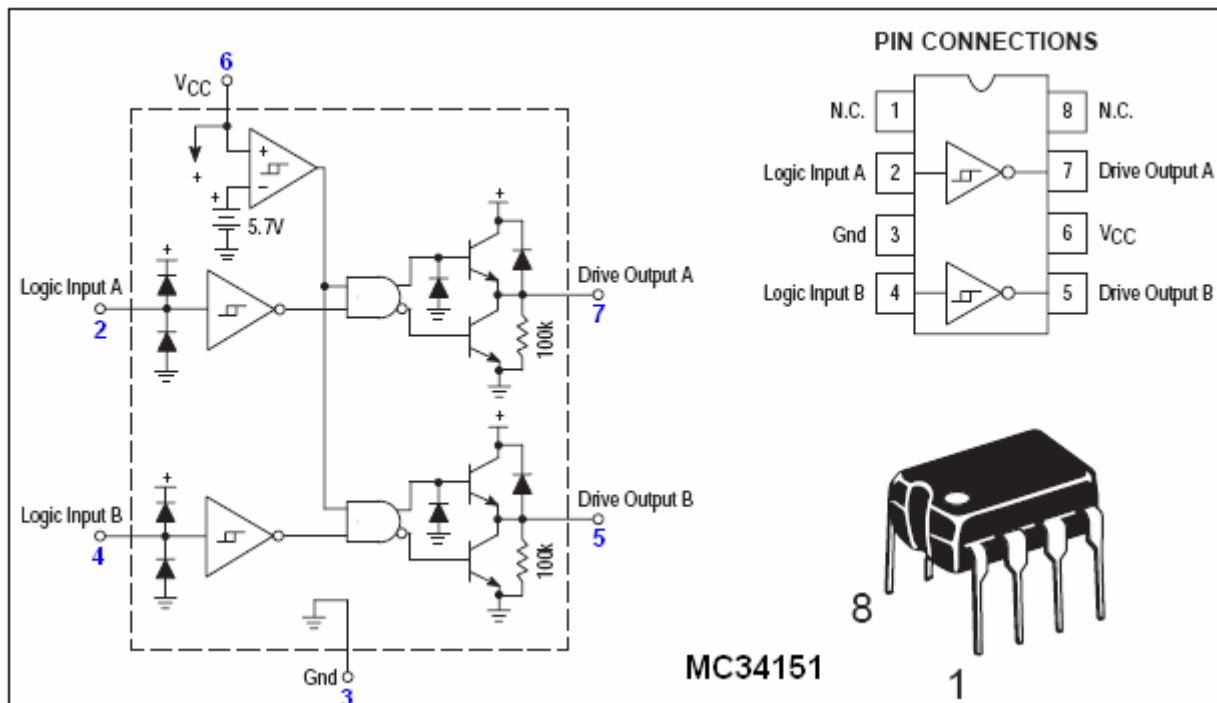

Phil's build of his circuit was implemented like this:



### Component List:

Component	Quantity	Description
10 ohm resistor 0.25 watt	1	Bands: Brown, Black, Black
100 ohm resistor 0.25 watt	2	Bands: Brown, Black, Brown
1K ohm resistor 0.25 watt	2	Bands: Brown, Black, Red
2.2K ohm resistor 0.25 watt	1	Bands: Red, Red, Red
4.7K ohm resistor 0.25 watt	1	Bands: Purple, Yellow, Red
10K ohm resistor 0.25 watt	1	Bands: Brown, Black, Orange
22K ohm resistor 0.25 watt	1	Bands: Red, Red, Orange
10nF capacitor	3	
5mF 440V (or higher) capacitor	1	Polypropylene
20mF 440V (or higher) capacitor	1	Polypropylene
47mF 25V capacitor	1	
330 mF 25V capacitor	1	
1N5819 Schottky barrier diode	1	
10-volt zener diode	1	
15-volt zener diode	1	
18-volt zener diode	1	
75-volt zener diode	2	
400-volt, 40 A rectifier bridge	1	
35-volt 1 A rectifier bridge	1	
MC34151 IC	1	
HEF4017B IC	1	
IRG4PH40UD transistor	1	
LEDs	10	Any type or alternatively, an LED array
100K ohm variable resistor	1	
Plastic knob for variable resistor	1	
240:18 volt mains transformer	1	150 mA or higher rated
10A switch 1-pole 1-throw	1	Toggle type, 120-volt rated
Veroboard or similar	1	Your preferred construction board or pcb
Wire terminals	4	Ideally two red and two black
Plastic box	1	Injection moulded with screw-down lid
Mounting nuts, bolts and pillars	8	Hardware for 8 insulated pillar mounts
Rubber or plastic feet	4	Any small adhesive feet
Sundry connecting wire	4 m	Various sizes

**Lawrence Tseung.** Lawrence has been presenting his theory of lead-out energy which indicates that excess energy is drawn from the environment when there is an impact. The method of producing this effect which he has followed is to create an unbalanced wheel and demonstrate that excess energy is produced. It should be stressed that energy is never created or destroyed and so, when he measures more energy in his device than the energy which he uses to power it, energy is not being created but is instead, being drawn in from the local environment. Lawrence has recently demonstrated a prototype to members of the public:

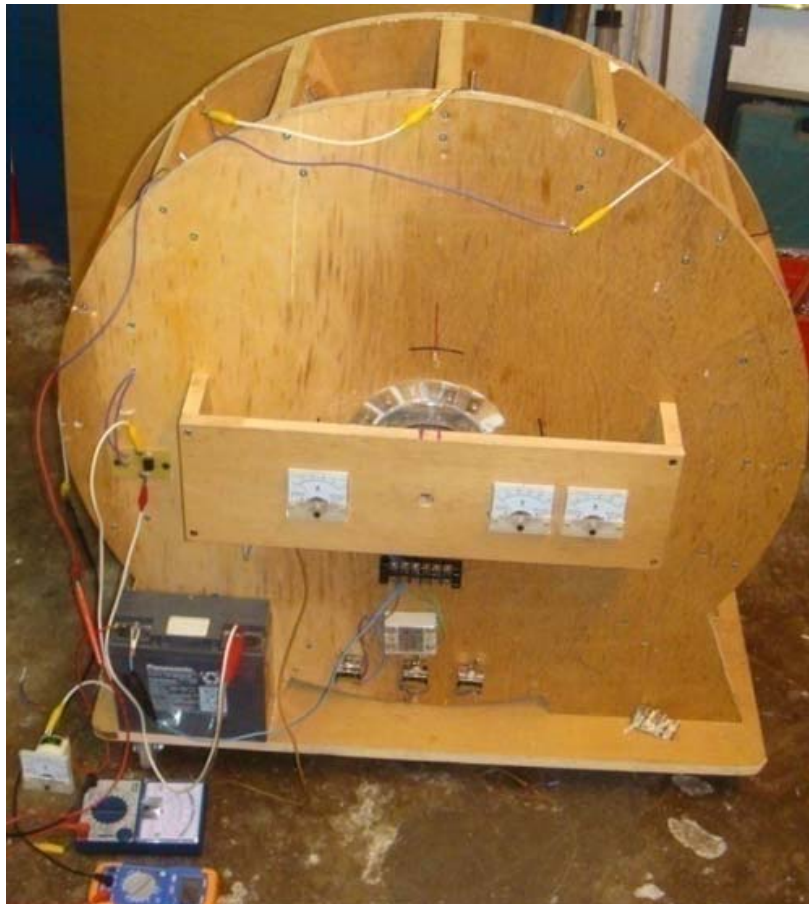

This simple device was demonstrated to have 3.3 times as much output power as the input power needed to make it operate. This is an early prototype which was demonstrated in October 2009 and Lawrence and his helpers are working on to produce more advanced models which have kilowatts of excess electrical power.

Mr Tseung remarks: "The **Lee-Tseung Lead-Out Energy Theory** was first disclosed to the world on 20th December 2004 at Tai Po, in Hong Kong. The Lead-Out Energy Theory basically says that one can lead-out (or bring-in) Energy from the surrounding environment into a Lead-Out Energy Machine. The total Input energy is equal to the sum of the Supplied Energy plus the Lead-Out Energy. For example, if the supplied energy is 100 units and the lead-out energy is 50 units, the device's total Input Energy will be 150 units. This means that the Output Energy can be more than the Supplied Energy of 100 units provided by the person using the device.

If we ignore the small loss of energy caused by less than 100% efficiency of the device itself, then the Output Energy will be the whole of the 150 units. If we use 50 of the output energy units and feed back 100 of the output units as the Supplied Energy, then that Supplied Energy can again lead-out another 50 units of excess output Energy for us to use. Thus a Lead-Out Energy Machine can continuously lead-out pollution-free, virtually inexhaustible and readily available energy for us to use. We do not need to burn any fossil fuel or pollute our environment. The two examples of Lead-Out energy which we access are Gravitational and Electron-Motion energy.

The Lead-Out Energy theory does not violate the Law of Conservation of Energy. The Law of Conservation of Energy has been used as a roadblock for the so called "Overunity" devices. The patent offices and the scientific establishment routinely dismiss an invention as belonging to the impossible "perpetual-motion machine" category if the inventor cannot identify the energy source of his invention.

We got the help of Mr. Tong Po Chi to produce a 60 cm diameter Lead-Out Energy machine in October 2009. The Output Energy of that device is greater than the Input Energy by a factor of 3 times. These results are confirmed by voltmeters and ammeters measuring the Input and Output energies.

The Tong wheel has been shown at two Open Shows in Hong Kong (Inno Carnival 2009 and Inno Design Tech Expo) in November and December 2009. Over 25,000 people have seen it. The Better Hong Kong Radio Show has video recorded it, the discussions being conducted in Chinese. At this time, the Tong wheel is at the Radio Studio available for experts to view and examine with their own instruments."

The Tong wheel has a diameter of 600 mm, 16 permanent magnets mounted on its rim and 15 air-core coils mounted around it on the stator. There is one position sensor. The coils can be switched to act as drive coils or as energy collection coils:

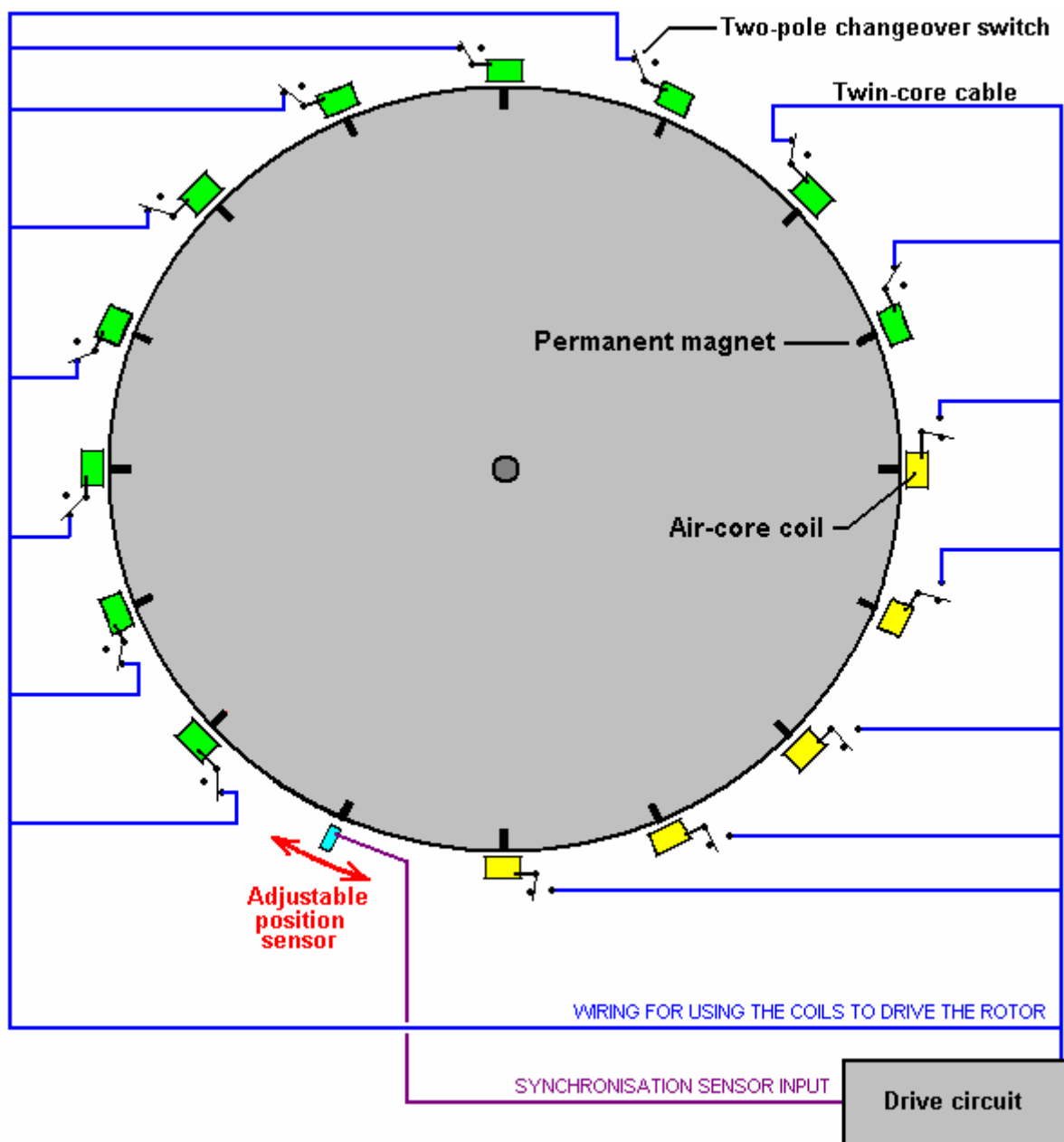

With this arrangement, if the positions the switches as shown for ten of the fifteen coils shown here, then they act as drive coils. The sensor is adjusted so that the drive circuit delivers a brief energising pulse to

those coils just after the magnets have passed their exact alignment position with the coils. This causes them to generate a magnetic field which repels the magnets, thrusting the rotor around.

The pulse is very brief, so very little power is needed to accomplish this pulsing. As mentioned before, any number of coils can be switched to provide this driving force. With this particular wheel construction by Mr Tong, the best number has been found to be ten drive coils.

The power pick-up is achieved by gathering the electricity generated in some of the coils as the magnets move past them:

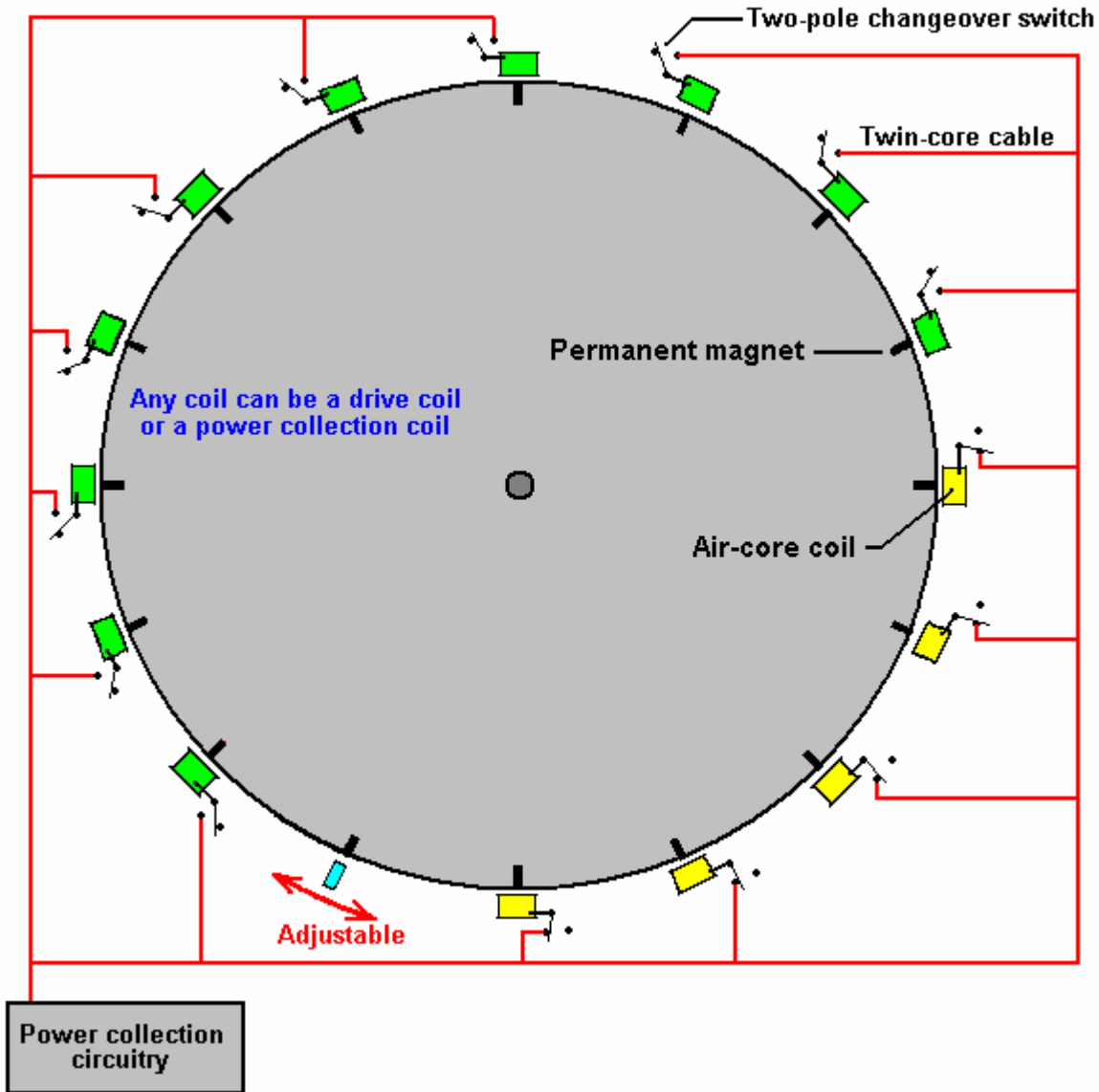

In this particular arrangement, five of the coils gather energy while ten provide the drive. For the sake of simplicity, the diagram shows the five collection coils adjacent to each other and while that would work, the wheel is better balanced if the drive coils are evenly spaced out around the rim. For that reason, this switching would actually be selected to give five sets of two drive coils followed by one pick-up coil as that gives a perfectly balanced thrust on the wheel.

The two diagrams above are shown separately in order to make it clear how the drive switching and the power pick-up switching are arranged. The full design arrangement and the balanced switching are shown in the following diagram which indicates how the full design is implemented on this particular implementation of the wheel design. The sensor can be a coil feeding a semiconductor switching circuit, or it can be a magnetic semiconductor called a Hall-effect device which can also feed a semiconductor circuit. An alternative would be a reed switch which is a simple mechanical switch encased in an inert gas inside a tiny glass envelope. Suitable switching circuits are described and explained in chapter 12 of this eBook.

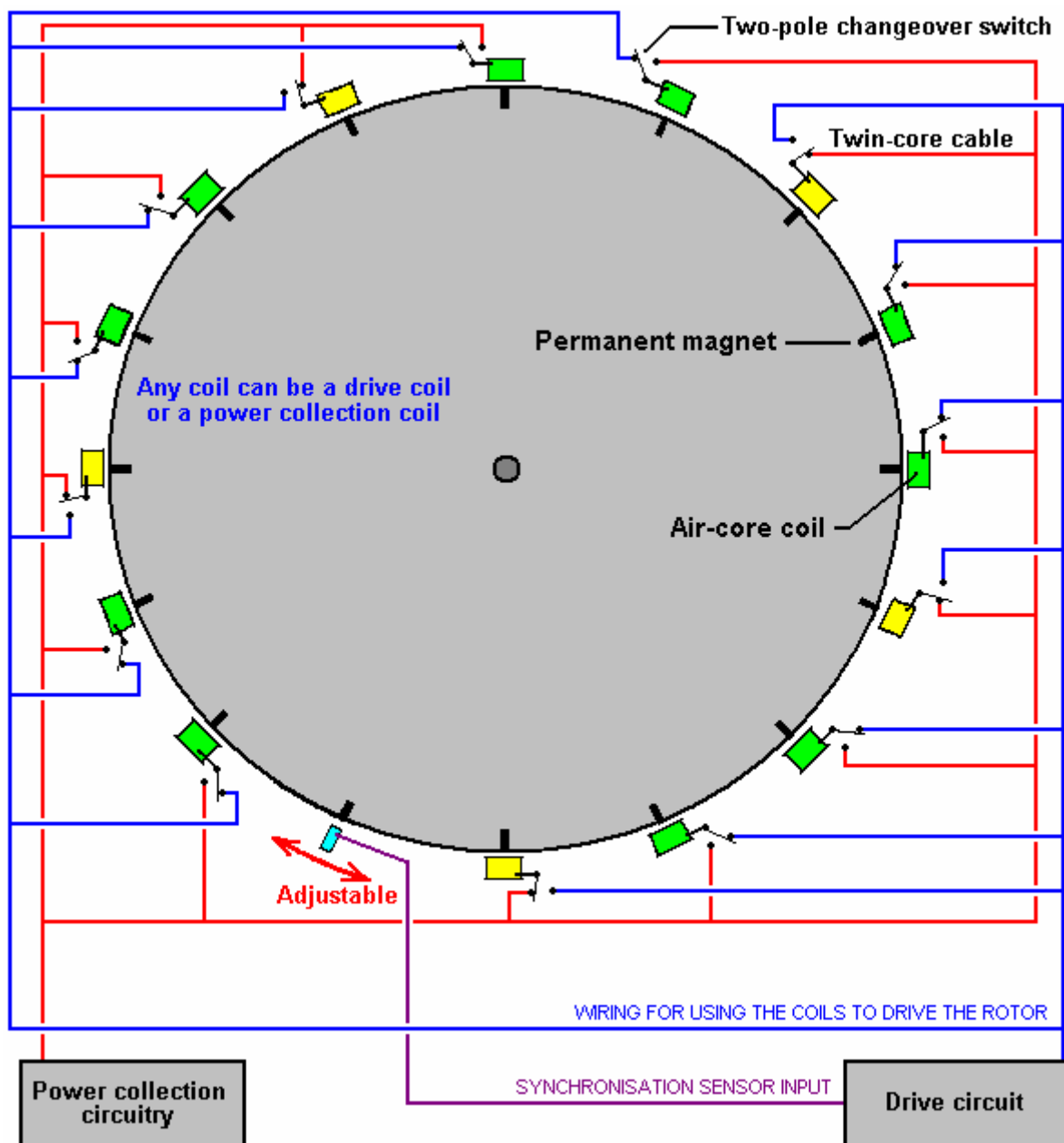

Mr Tseung remarks that the large wheel size is due to the fact that the Pulse Force takes time to impart the impulse to the wheel and lead-out energy from the environment into the system. If you want to see this actual wheel, you can email Dr. Alexandra Yuan at [ayuan@hkstar.com](mailto:ayuan@hkstar.com) to make an appointment. The Tong wheel is located at the Better Hong Kong Radio Studio in Causeway Bay, Hong Kong. Just say that you want to see the Lead-Out Energy Machine. The demonstration can be in English or in Chinese. Ideally, there should be a group of at least six visitors with one or more being a qualified engineer or scientist, and you are welcome to bring your own cameras and/or test equipment. It is planned to produce a version which has a 300 watt output, and another with a 5 kilowatt output. Educational kits are also planned.

If you decide to replicate this particular design, then to raise the output power level you might consider putting another set of coils around the wheel and either using them as fifteen additional energy pick-up coils or alternatively, pulsing the wheel twice as often. Adding one or more additional rotor discs to the same rotating shaft is also an option and that has the advantage of increasing the rotor weight and improving the effect of the impulses on the rotor.

The diameter of the wire used to wind the coils is a design choice which has a wide scope. The thicker the wire, the greater the current and the larger the impulse given to the wheel. The coils are normally connected in parallel as shown in the diagrams.

Because of the way magnetic field strength drops off with the square of the distance, it is generally considered good design practice to make the coils one and a half times as wide as they are deep, as indicated in the diagrams above.

\*\*\*\*\*

It is felt that some specific information on alternators would be helpful at this point. My thanks goes to **Professor Kevin R. Sullivan**, Professor of Automotive Technology, Skyline College, San Bruno, California, who has given his kind permission for the reproduction of the following training material from his excellent web site at <http://www.autoshop101.com/> which I recommend that you visit. The following material is his copyright and All Rights are Reserved by Professor Sullivan.

### **UNDERSTANDING THE ALTERNATOR**



#### **The Charging System**



A vehicle charging system has three major components: the **Battery**, the **Alternator**, and the **Regulator**. The alternator works together with the battery to supply power when the vehicle is running. The output of an alternator is direct current (DC), however the alternator actually creates AC voltage which is then converted to DC as it leaves the alternator on its way to charge the battery and power the other electrical loads.

#### **The Charging System Circuit**



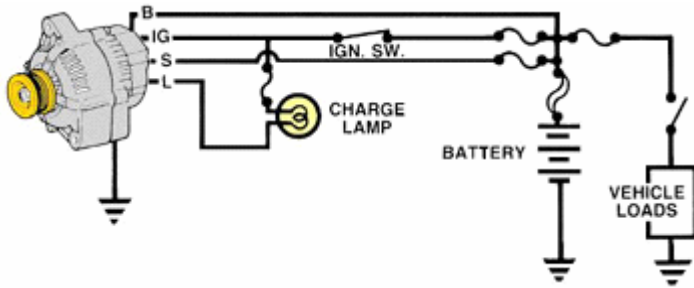

Four wires connect the alternator to the rest of the charging system:

- 'B' is the alternator output wire that supplies current to the battery.
- 'IG' is the ignition input that turns on the alternator/regulator assembly.
- 'S' is used by the regulator to monitor charging voltage at the battery.
- 'L' is the wire the regulator uses to ground the charge warning lamp.

### Alternator Terminal IDs

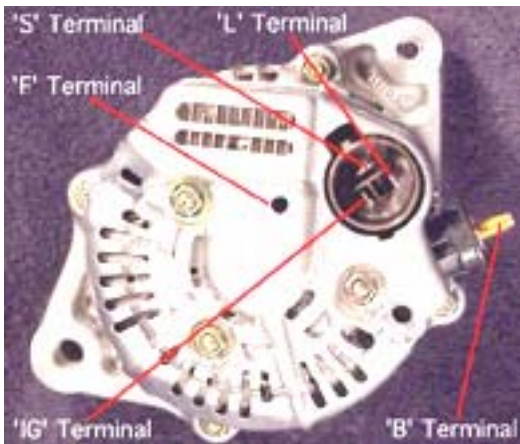

- 'S' terminal: Senses the battery voltage
- 'IG' terminal: Ignition switch signal turns regulator ON
- 'L' terminal: Grounds warning lamp
- 'B' terminal: Alternator output terminal
- 'F' terminal: Regulator Full-Field bypass

### The Alternator Assembly

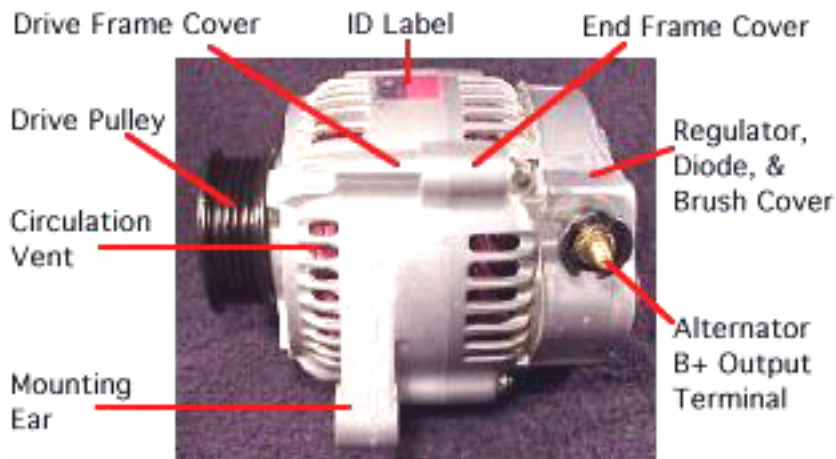

### Alternator Overview:

The alternator contains:

A rotating field winding called **the rotor**.

A stationary induction winding called **the stator**.

A diode assembly called **the rectifier bridge**.

A control device called **the voltage regulator**.

Two **internal fans** to promote air circulation

### **Alternator Design**



Most regulators are on the inside of the alternator. Older models have externally mounted regulators.

Unlike other models, this model can be easily serviced from the rear of the unit. The rear cover can be removed to expose internal parts.

However, today's practice is to replace the alternator as a unit, should one of it's internal components fail.

### **Drive Pulley**



Alternator drive pulleys either bolt on or are pressed on the rotor shaft. Both 'V' and Multi-groove types are used. Please note this alternator does not have an external fan as part of the pulley assembly.

While many manufacturers do use an external fan for cooling. This alternator has two internal fans to draw air in for cooling.

### Inside the Alternator

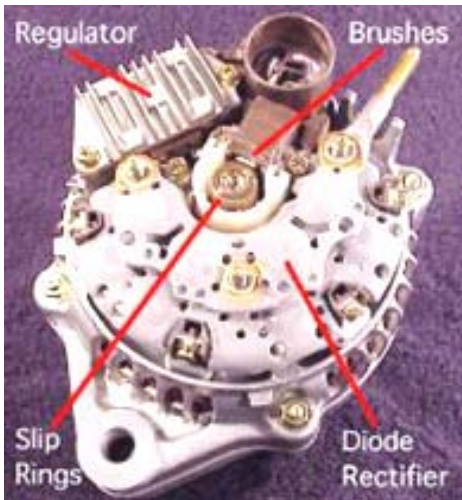

Removal of the rear cover reveals:

**The Regulator** which controls the output of the alternator.

**The Brushes** which conduct current to the rotor field winding.

**The Rectifier Bridge** which converts the generated AC voltage to a DC voltage.

**The Slip Rings** (part of the rotor assembly) which are connected to each end of the field winding.

### Brushes

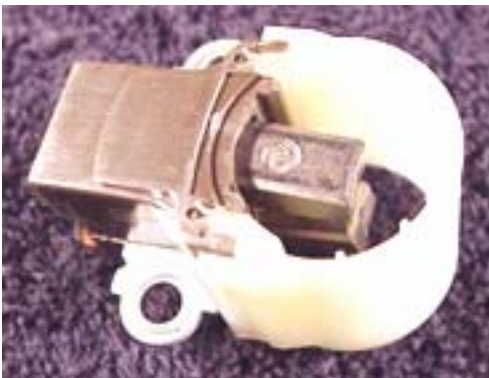

Two slip rings are located on one end of the rotor assembly. Each end of the rotor field winding is attached to a slip ring. This allows current to flow through the field winding.



Two stationary carbon brushes ride on the two rotating slip rings. These brushes are either soldered or bolted in position.

### Electronic IC Regulator



The regulator is the brain of the charging system. It monitors both the battery voltage and the stator voltage and, depending on the measured voltages, it adjusts the amount of rotor field current so as to control the output of the alternator.

Regulators can be mounted in an internal or an external position. Nowadays, most alternators have a regulator which is mounted internally.

### Diode Rectifier



The **Diode Rectifier Bridge** is responsible for the conversion or rectification of AC voltage to DC voltage.

Six or eight diodes are used to rectify the AC stator voltage to DC voltage. Half of these diodes are used on the positive side and the other half on the negative side.

### Inside the Alternator





Opening the case reveals:

The **rotor winding assembly** which rotates inside the **stator winding**. The rotor generates a magnetic field and the stator winding develops voltage, which causes current to flow from the induced magnetic field of the rotor.

### The Rotor Assembly

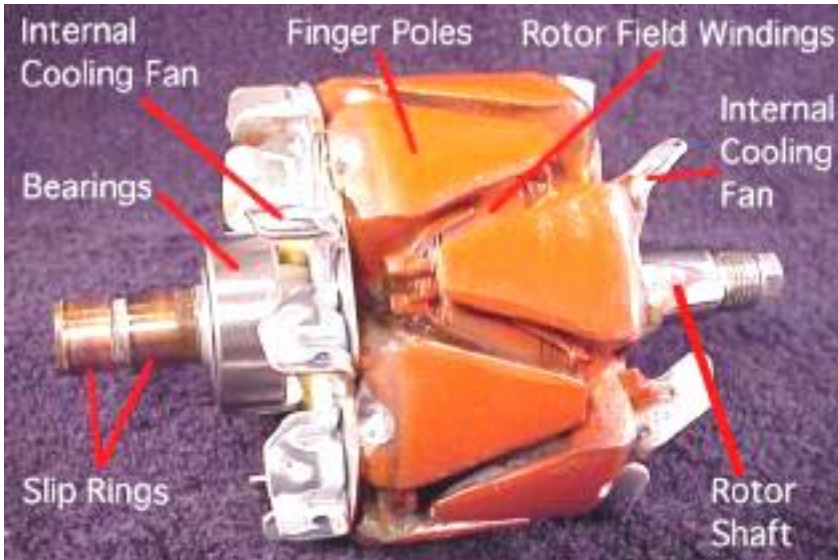

A basic rotor consists of an **iron core**, a **coil winding**, two **slip rings**, and two claw-shaped **finger pole pieces**. Some models have support bearings and one or two internal cooling fans.

The rotor is driven or rotated inside the alternator by an engine (alternator) drive belt.



The rotor contains the field winding wound over an iron core which is part of the shaft. Surrounding the field coil are two claw-type finger poles. Each end of the rotor field winding is attached to a slip ring. Stationary brushes connect the alternator to the rotor. The rotor assembly is supported by bearings. One on the shaft and the other in the drive frame.

### Alternating Magnetic Field



The rotor field winding creates the magnetic field that induces voltage in the stator. The magnetic field saturates the iron finger poles. One finger pole becomes a North pole and the other a South pole.

The rotor spins creating an alternating magnetic field, North, South, North, South, etc.

### Stator Winding

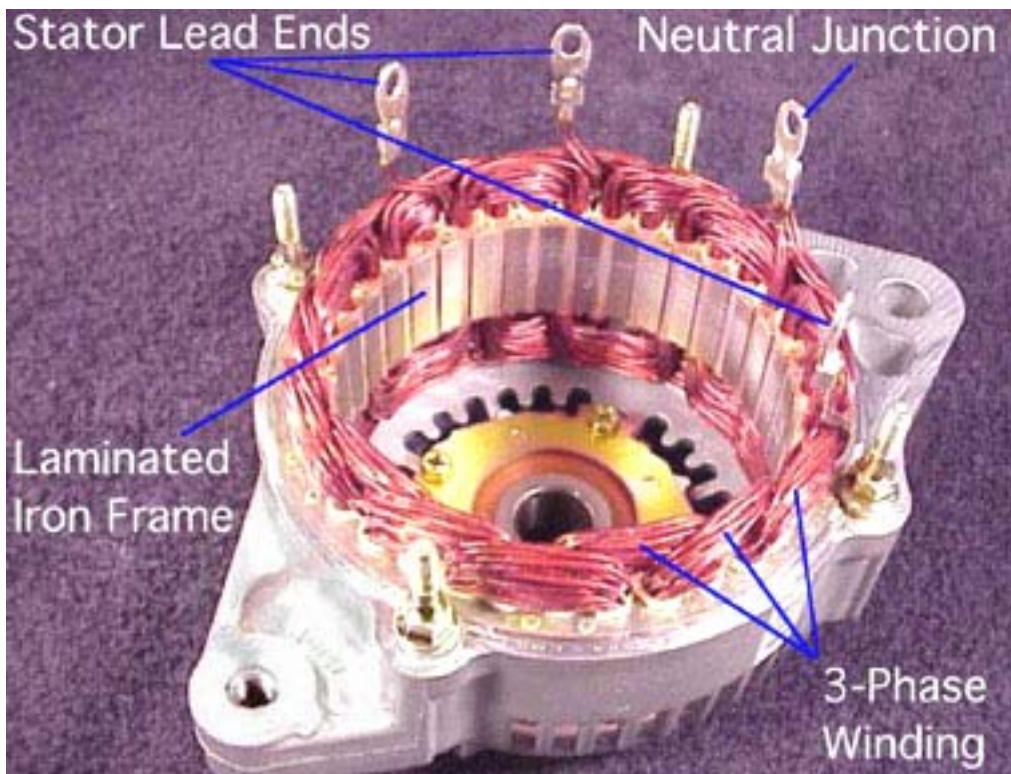

The stator winding looks like the picture above.

## Rotor / Stator Relationship



As the rotor assembly rotates within the stator winding: The alternating magnetic field from the spinning rotor induces an alternating voltage into the stator winding. The strength of the magnetic field and the speed of the rotor affect the amount of voltage induced in the stator.

## Stator Windings

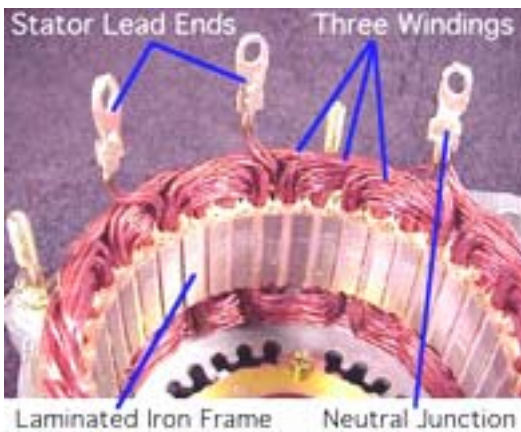

The stator is made with three sets of windings. Each winding is placed in a different position compared with the others. A laminated iron frame concentrates the magnetic field. Stator lead ends output current to the diode rectifier bridge.

The Neutral Junction in the Wye design can be identified by the 6 strands of wire.

## 3-Phase Windings

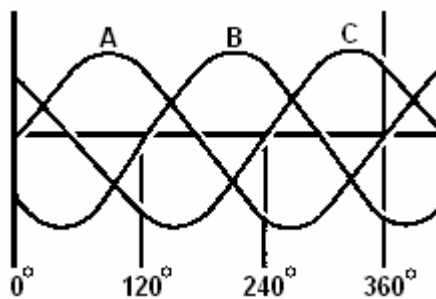

The stator winding has three sets of windings. Each winding is formed into a number of evenly spaced coils around the stator core.

The result is three overlapping single-phase AC sine-wave current peaks, A, B, C.

These waves add together to make up the total AC output of the stator. This is called three-phase current.



Three-phase current provides a more even current output than a single-phase output would do.

### Stator Designs

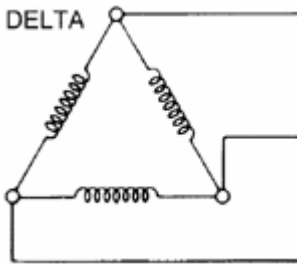

Delta-wound stators can be identified by having only three stator leads, and each lead will have the same number of wires attached.

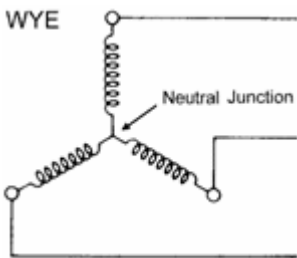

Wye-style stators have four leads. One of the leads is called the Neutral Junction. The Neutral Junction is common to all the other leads.

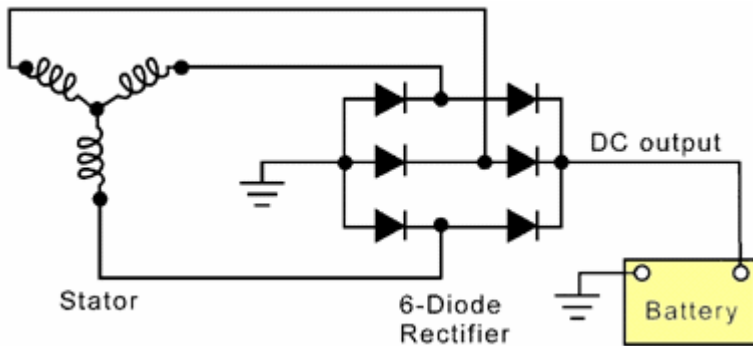

Wye-wound stators have three windings with a common neutral junction. They can be identified because they have 4 stator lead ends. Wye wound stators are used in alternators that require high-voltage output at low alternator speeds. Two windings are in series at any one time during charge output.

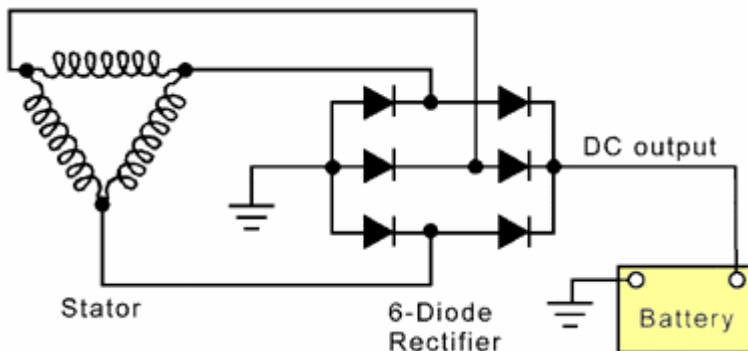

Delta-wound stators can be identified because they have only three stator lead ends. Delta stators allow for higher current flow being delivered at low RPM. The windings are in parallel rather than in series as the Wye designs have.

### Diode Rectifier Bridge Assembly

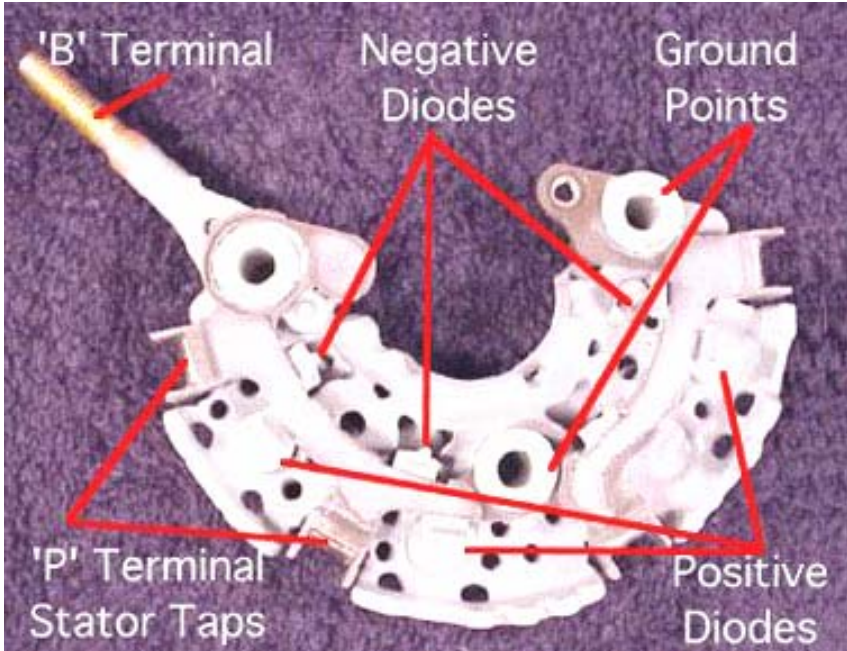

### Rectifier Operation:

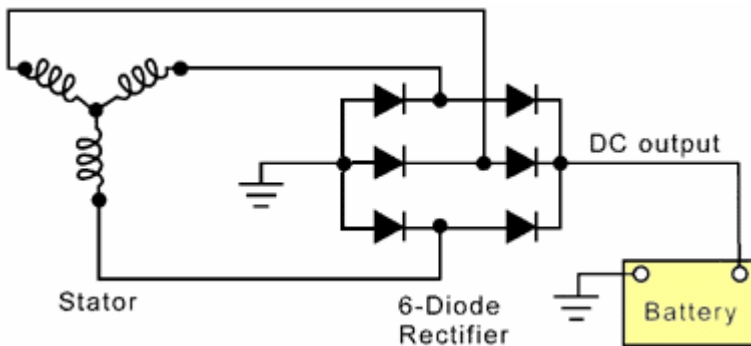

Two diodes are connected to each stator lead. One positive the other negative. Because a single diode will only block half of the AC voltage, six or eight diodes are used to rectify the AC stator voltage to DC voltage.

Diodes used in this configuration will redirect both the positive and negative parts of the AC voltage in order to produce a better DC voltage waveform. This process is called 'Full - Wave Rectification'.

## Diodes

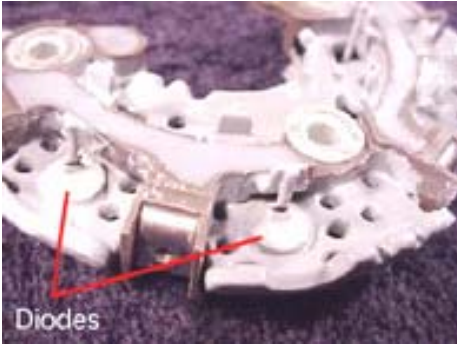

Diodes are used as one-way electrical check valves. They pass current in only one direction, and never in the other direction. Diodes are mounted in a heat sink to dissipate the heat generated by the current flow. Diodes redirect the AC voltage and convert it into DC voltage, so the battery receives the correct polarity.

### Rectifier Operation:

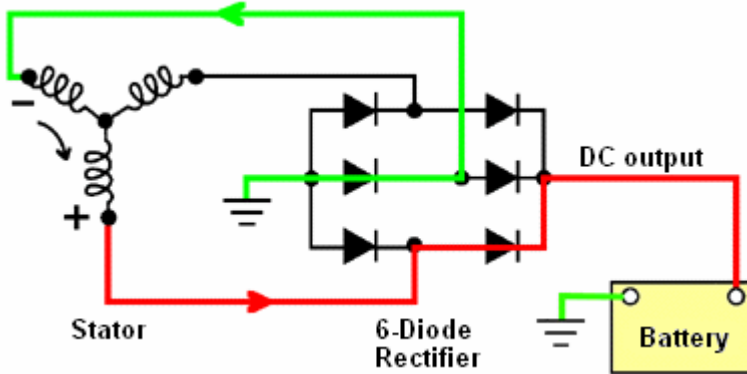

The red path is the positive current passing through the rectifier as it goes to the positive battery terminal. The path shown in green completes the circuit.

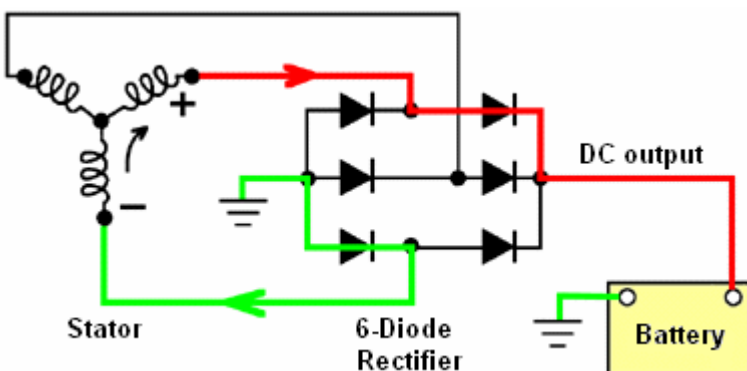

As the rotor continues its movement, the voltages generated in the three windings, change in polarity. The battery is still fed current, but now a different winding feeds it. Again, the red path shows the current flow to the battery and the green path shows how the circuit is completed. The same charging continues even though different windings and diodes are being used.

## Electronic Regulator

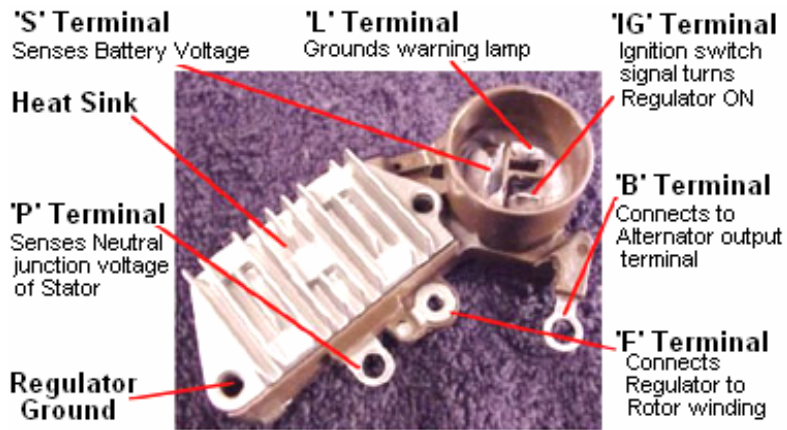

The regulator attempts to maintain a set charging voltage. If the charging voltage falls below this point, the regulator increases the field current, which strengthens the magnetic field, resulting in a raising of the alternator output voltage.

If the charging voltage rises above this point, the regulator decreases the field current, thus weakening the magnetic field, producing a lowering of the alternator output voltage.

### Regulator Types:

Two regulator designs can be used. The first type is:

The **Grounded Regulator** type. This type of regulator controls the amount of current flowing through the battery ground (negative) into the field winding in the rotor:

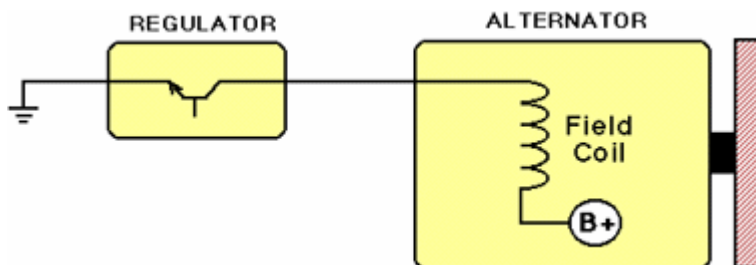

The second type is:

The **Grounded Field** type. This type of regulator controls the amount of current flowing from the Battery Positive ('B+') into the field winding in the rotor.

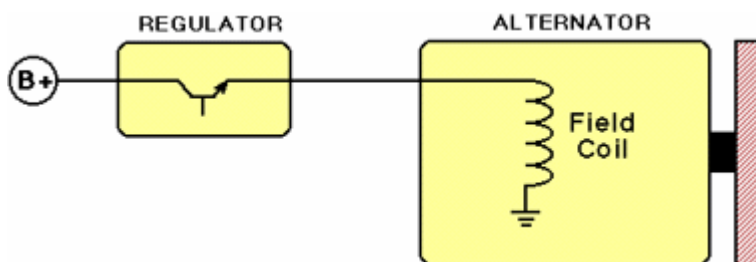

## The Working Alternator

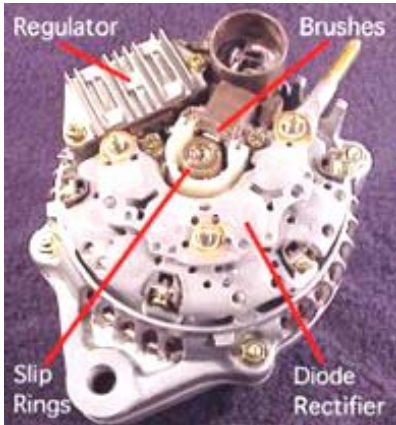

The **regulator** monitors battery voltage and controls current flow to the rotor assembly.

The **rotor** produces a magnetic field.

Voltage is induced in the **stator windings**.

The **rectifier bridge** converts the AC stator voltage to DC output voltage for use by the vehicle.

\*\*\*\*\*

The website <http://islandcastaway.com/stuff/windpower/Alternator%20Secrets.htm> has the following very interesting information from an unknown American author:

### **INTRODUCTION**

Since 1980, alternators have replaced generators in motor vehicles. The reasons are many: output current can be produced at lower rpm, voltage can be more accurately controlled with solid state regulators, alternators need less maintenance, and they cost less to manufacture.

When modified, auto alternators can provide variable direct current at 0 to 120 volts for battery charging, hot charging, light arc welding, or for running AC-DC appliances and lights. Another simple modification provides AC power to run some transformer-operated appliances. If you know the secrets of its operation and the modifications possible, the small low-cost alternator can become a versatile power plant.

### **BASIC CONSTRUCTION**

The old-fashioned generator contains a wound stator which produces a constant magnetic field in which a revolving coil of wire, called an armature, turns. A commutator on one end of the armature made up of many individual brass segments passes the generated current to the outside world through carbon brushes.

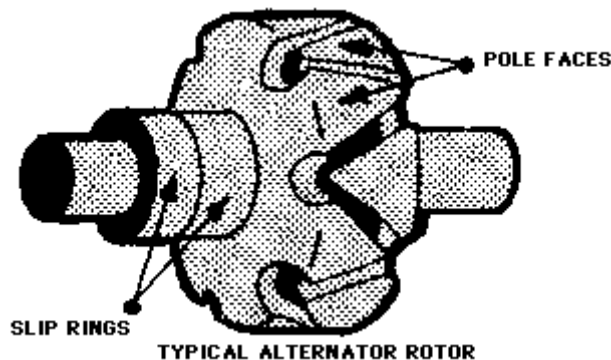

Because commutator segments must be electrically insulated from one another, they can not be fabricated from a single block of metal. Each commutator segment must be individually attached to the armature shaft.

This is a source of mechanical weakness. When the armature is rotated at high rpm, centrifugal force can cause the commutator to explode, throwing segments in all directions.

To prevent explosions, a generator is usually driven at less than the engine speed. An vehicle engine may turn at 5,000 rpm, but the generator must be geared down to run at a maximum of 2,500 rpm for safety's sake. As a result, the generator turns so slowly at low engine rpm that it produces little or no current.

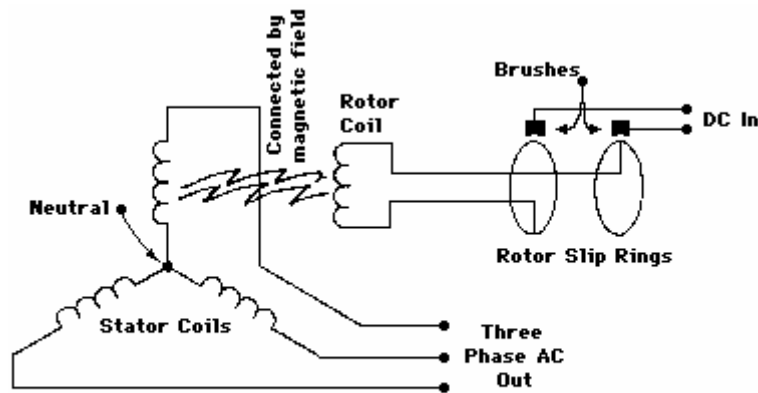

**ELECTRICAL SCHEMATIC OF A TYPICAL ALTERNATOR**

Like the generator, a modern alternator contains both moving and stationary coils of wire. However, in the alternator, the moving coil, called the rotor, uses current supplied through slip rings to generate a moving magnetic field. Power is extracted from the stationary field coils.

Slip rings replace the weak generator commutator. The rotor coils themselves are encased in a strong soft iron shell making the whole assembly much stronger than the generator armature. The net result is that alternators can be driven at much higher speeds without any danger of explosion. In fact, alternators are usually driven at up to twice engine speed some running at 8,000 rpm or more. At low engine rpm, the geared-up alternator turns much faster than a comparable geared-down generator. The net result is that the alternator can begin producing useful charging current at lower engine rpm than the generator can.



**Solid State Diode**

A coil of wire rotating in a magnetic field produces an alternating current with a frequency dependent on how fast the coil turns, one cycle being produced per revolution. A generator armature uses a commutator to mechanically switch rotating windings in and out of automobile's electrical system to produce direct current.

The three separate stationary windings of the typical auto alternator produce three-phase alternating current. Rather than use a commutator to mechanically convert AC to DC, the alternator uses six diodes in a full-wave bridge rectifier circuit. In essence the diodes are solid state switches with no moving parts, making them maintenance-free and explosion proof.

The alternator output voltage can be controlled or regulated by varying the rotor current. Regulators sample the output voltage and automatically change the intensity of the rotating magnetic field by adjusting the current fed to the rotor through the slip rings. The adjustments are made in such a way so as to bring the output voltage to the desired level.

### **THREE-PHASE POWER**

Surprisingly, alternators are constructed with three sets of field windings positioned evenly at 120 degree intervals inside the frame. Such construction produces three-phase AC. But why three-phase?

If we look at the effect of diodes on a single-phase AC current, we see that the output is a series of DC pulses. True direct current is completely smooth. The output of the diodes (rectified AC) is bumpy, and so is said to possess ripple

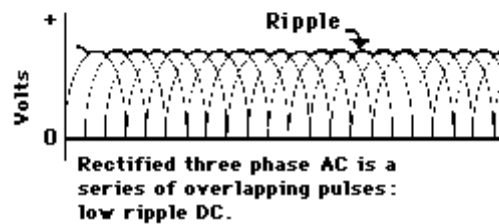
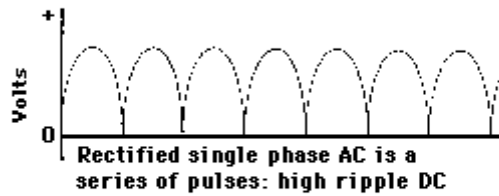
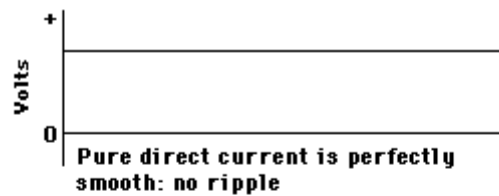

When the rectified DC from each of the three-phase windings is added together or superimposed, the peaks overlap to produce a much cleaner DC with much less ripple. Lead-acid batteries last longer when charged with pure DC than high ripple rectified DC. Generators may be a mechanical and electrical nightmare, but they put out very clean DC. Three-phase windings were designed into alternators to produce DC of greater purity.

Many alternators connect one lead of each winding to a common point called a neutral. The other lead of each winding is connected to a pair of diodes. Three windings, each using two diodes, accounts for the six diodes found on most alternators.

Newer alternators, particularly high current models, use two additional diodes on the neutral connection, to provide a sample of the alternator output voltage which is then used by the regulator.

In the future, internal mechanical construction, electrical circuits, regulator operation and physical location will probably change somewhat but basic alternator theory will not change. The exact details for the alternator you have can usually be found in a standard vehicle repair manual such as Motor's or Chilton's. Often you will get instructions on dismantling and repairing alternators as well.



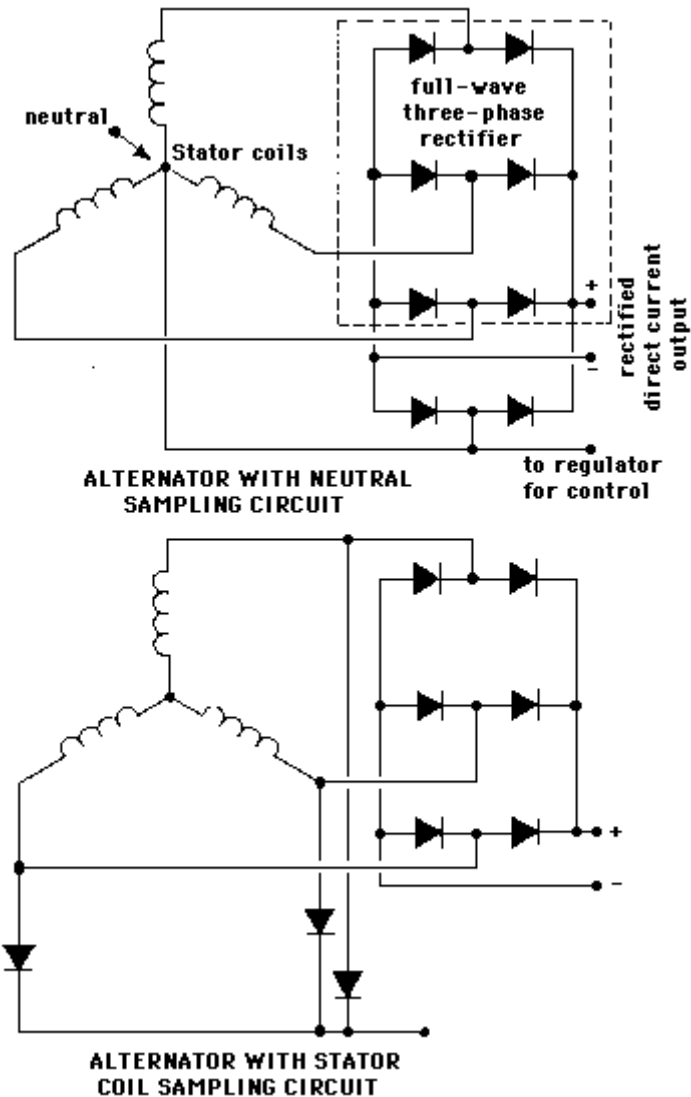

The diagrams shown here are general and should apply to all alternators.

## REGULATORS

Early alternators used relays to regulate their output voltage much like those used on generators. When cheaper, more reliable, solid-state devices became available, electronic regulators became standard.

Although most regulators are factory set to force an alternator to produce 12 to 14 volts, they can be modified or new regulators custom built to provide almost any voltage up to 130 volts once their operation is understood.

If we were to run an alternator at some fixed rpm, we would find that changing the intensity of the rotating magnetic field would change the output voltage of the alternator. We can change that magnetic field by changing the amount of current flowing through the slip rings into the rotor. Since the resistance of the rotor windings is constant, merely changing the input voltage to the rotor will change the current flowing into the rotor by a proportionate amount.

Suppose we have alternator-spinning at 2,000 rpm. We have it attached to some electrical load drawing, say, 10 amps at 12 volts. Let's assume that the rotor is using 1 amp at 4 volts. Suppose we increase the electrical load: so that we now need 15 amps. Due to internal electrical resistance of the whole system, the voltage falls to 11 volts. To get the output voltage back up to 12 volts we must increase the rotor magnetic field intensity. So we adjust the rotor voltage up to 6 volts and in doing so, we find the rotor is now drawing 1.5 amps of current. This increased current results in an increased magnetic field which at 2,000 rpm gives an output of 15 amps at 12 volts. It is the job of the regulator to make these adjustments quickly and automatically.

Let's suppose that we set the rotor current at its maximum value, say 3 amps at 12 volts, and then we vary the rpm. At low rpm, the output voltage might be only five volts. As the rpm increases, the output voltage would hit 12 volts then 25, then 50, and at top end, over 100 volts. Alternators can sometimes put out 140 volts when driven at their top rpm.

As you can imagine, when the alternator is running at low rpm, the alternator is putting maximum voltage and current into the rotor so that the alternator output voltage will come up to 12 volts. When the rpm starts to pick up so that the voltage starts to climb above 12, the regulator starts cutting back the voltage and current into the rotor. At very high rpm, the regulator is supplying the rotor with very little current, so that the output voltage remains at a constant 12 volts.

An electronic regulator provides continuous and instantaneous adjustment of rotor current by sampling the alternator output voltage and by comparing it to it's own internal standard reference voltage. In the following circuit diagram, when output falls, a small current is sent to transistor **B** which amplifies it and sends it to transistor **A** which acts as a valve in controlling the heavy current flow from the battery to the rotor.

Input voltage to the regulator is usually a steady 12 volts whereas output to the rotor varies from zero to 12 volts to control rotor current. Many rotors have a winding resistance of about 3 or 4 ohms, which causes a current of 3 to 4 amps to flow at 12 volts (calculated with Ohm's law)

Suppose that to get 12 volts out of an alternator we need to pump 2 amps of Direct Current into the alternator's rotor which has an internal resistance of 3 ohms. What would the rotor voltage have to be? We can calculate it with Ohm's law which says Volts = Amps x Ohms, so in our example

$$\begin{aligned} \text{Volts} &= 2 \text{ amps} \times 3 \text{ ohms, or} \\ \text{Voltage} &= 6 \text{ volts} \end{aligned}$$

The regulator passes 2 amps but has to eat up the difference between supply voltage, 12 volts, and rotor voltage, 6 volts - an excess of 6 volts. How much power is this? We can do another simple calculation:

$$\begin{aligned} \text{Watts} &= \text{Amps} \times \text{Volts, so} \\ \text{Watts} &= 2 \text{ amps rotor current} \times 6 \text{ volts difference} = 12 \text{ watts} \end{aligned}$$

This 12 watts of power is turned into heat, and if the regulator is to be kept cool and working properly, it must have heat-dissipating fins or should be mounted on a large heat sink such as a Bumper (fender) or firewall partition where this destructive heat can be carried away.

Regulators use Zener diodes to provide a stable reference voltage. A voltage divider - the three resistors labelled **C** - extracts a preset fraction of the voltage for comparison against the Zener. For example, a regulator might have a 6 volt Zener in its circuit. To provide a regulated 12 volts, the resistive voltage divider is set to extract 1/2 of the sample voltage. When 12 volts is produced, half of that 12 volts (six volts), is compared to the 6 volt Zener. If they are equal, then no change is made to the rotor current. If the output voltage falls to 8 volts, then the 6-volt Zener voltage is compared to half of that 8 volts, (4 volts), and the regulator output current is increased to compensate. If output rises above 12 volts, then the regulator transistor is shut down enough to bring the output voltage back down.

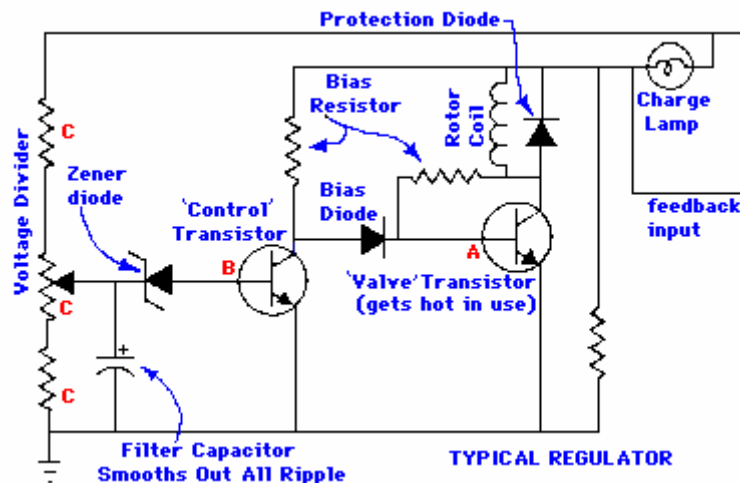

Electronic regulators are superior to the old triple relay regulators used on generators. Obviously, there are no contacts to burn. While the older regulators would click in and out at the rate needed to hold output fairly steady, while the solid-state regulators provide smooth quiet service, causing small, continuous changes in rotor current. As long as the electronic unit is kept cool, it should never need any servicing or replacement of parts.

Alternator rotors are usually very rugged. Specially shaped poles create multiple magnetic poles from a single rotor winding. For instance, some Delco alternators have 8 alternating pairs of poles folded back from either end. With a single revolution of the rotor, the stator windings are hit with eight magnetic fields, producing eight cycles of alternating current. This is probably done to increase alternator output at very low rpm with limited rotor current. At normal running speeds the frequency of the alternating current fed to the diodes is usually several hundred cycles per second. HUNDREDS quite unlike the 60 cycles per second which you get from a US mains socket.

Again, alternators are exceptionally strong allowing them to be overdriven at high rpm. They will produce useable current at lower rpm, and high voltage at high rpm if the rotor current is turned at maximum speed. High frequency, three-phase AC, is fed to solid-state diodes to produce a low ripple DC output.

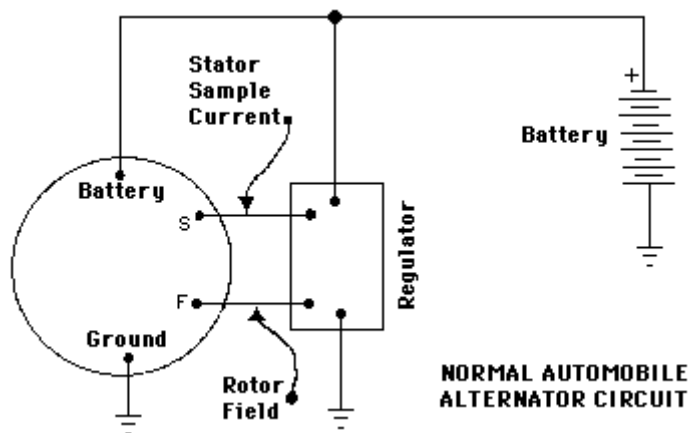

### **MODIFICATIONS**

You'll see ads in many magazines promoting a simple device which when added to an vehicle alternator will allow you to get 3,000 watts of DC to run AC-DC type appliances such as power drills, saws, and lights. This so-called wonder has been sold at prices from a few dollars to more than \$25. You can build one for a couple dollars.

The secret of this magical little box is extremely simple. A switch bypasses the regulator putting 12 volts into the alternator rotor while transferring the alternator output from the vehicle circuit to a mains socket installed in the box. When the engine rpm increases, the voltage rises to 120 volts. The device, therefore is nothing more than a switch and a US mains socket.

As we just discussed, alternator output voltage increases as the revs go up. It is the job of the regulator to cut back rotor current as the revs increase so that alternator output voltage stays at a constant 12 to 14 volts. The switch in the wonder box prevents the regulator from doing its job. As the revs increase so does the alternator output voltage. Some of the more expensive boxes have a volt meter to monitor the voltage being produced.

The diodes, also called rectifiers, are solid-state devices which have low internal resistance --- that is, they eat up very little of the current flowing through them. These days solid-state diodes are easy to manufacture and so they are low cost devices.

Diodes have two ratings: PIV and amperage. The amperage rating tells you how much current the diode can handle continuously. All diodes have some resistance, and at high current levels some power is converted to heat by this resistance. The ability to get rid of the waste heat determines how much current the diode can handle. Remember, waste heat is determined by the current flowing and it has nothing whatsoever to do with voltage.

The PIV, "Peak Inverse Voltage" rating tells you how much voltage the diode can withstand before its internal insulation breaks down. A diode rated at 100 PIV can be used in circuits to 100 volts. A voltage of 200 volts at a tiny fraction of an amp for even a thousandth of a second (a voltage spike) can destroy the diode.

It's usually a good idea to under-run diodes. If you want a diode to handle 10 amps at 100 volts, then it would be wise to use a diode rated at 15 amps and 200 PIV. Diodes used on modern alternators can usually handle the high voltage. It is entirely possible, however, that when you bring the alternator voltage up that you could blow the diodes in the alternator due to exceeding the voltage rating of the diodes. This means having to replace the diodes. They're not expensive, but it can be a hassle pressing out old diodes and putting in new ones. Refer to a repair manual for detailed information.

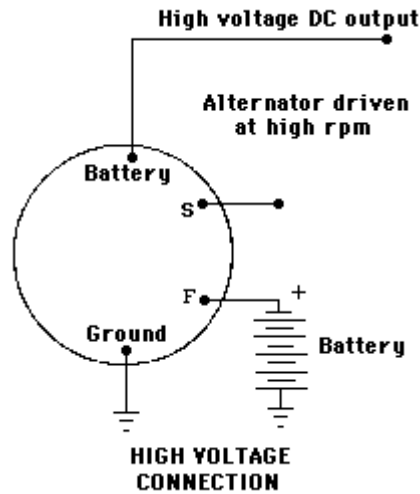

If we have a 30 amp alternator and we've revved it up to get 120 volts we can calculate the power available:

$$\text{Watts} = \text{Volts} \times \text{Amps}, \text{ or } \text{Watts} = 120 \text{ volts} \times 30 \text{ amps} = 3,600 \text{ watts.}$$

The \$25.00 control box that you must buy (so the ads say) consists of a four-pole double-throw switch, a 30 amp fuse, a main socket, and an optional 0-150 volt DC volt meter. Throwing the switch puts 12 volts into the alternator rotor through one set of contacts, cuts the regulator out of the circuit with another pair of contacts, and switches the alternator output from the auto electrical system through a 30 amp fuse to a standard outlet with another pair of switch contacts. A volt meter can be connected across the output to show how fast the engine must turn to give 120 volts.

When producing the higher voltage, the battery supplies 3 to 4 amps to the alternator but receives no charge in return. Even with this drain, the unit can be run for many hours before the battery comes noticeably discharged. But remember! You cannot run the system this way indefinitely. An 80 Amp-Hour battery would become fully discharged in 20 hours with a 4 amp draw. At some point you'll have to switch back to normal operation to recharge the battery. And! lead-acid batteries can be seriously damaged if allowed to become fully discharged.

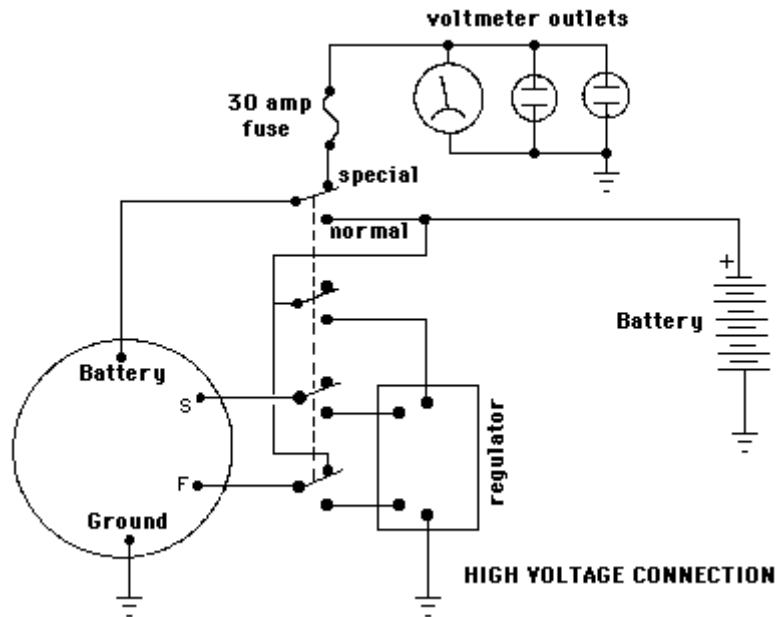

Suppose we're producing 3,600 watts. Since 746 watts equals one horsepower, it's a simple matter to calculate the mechanical power needed:

$$\text{Horsepower} = \text{Watts} / 746, \text{ or in this example, } \text{Horsepower} = 3,600 \text{ watts} / 746 = 4.8 \text{ horsepower}$$

By the time you add power lost in bearings and fan windage, you'll probably need 5.5 horsepower.

Revving up a vehicle engine just to produce 5 horsepower is wasteful. Many people have found that a small power plant can be built from a 5 to 8 horsepower engine, an alternator, a regulator, a motorcycle battery, switches, etc. The engine's governor can be set to hold a steady rpm, and for longer periods of use, this small power plant should use less fuel since it is running closer to full load.

When building a power plant, it is advisable to get an alternator from a large late-model air-conditioned car. Many of these units can produce 50 to 60 amps which can be used for light arc-welding. It is best to include a 0-60 amp ammeter in your power plant circuit to be sure you come close to but do not exceed the alternator's capacity. While it is possible to burn out the alternator windings, the diodes usually melt first.

Since petrol engines seldom run above 3,500 rpm and since an alternator must turn about 5,000 rpm to produce 120 volts, the unit must be geared up. Putting a larger pulley on the engine will achieve a gearing-up proportional to the ratio of the pulley diameters. For instance, if an engine running at 2,600 rpm must be geared-up to turn the alternator at 5,200 rpm, then we need to gear the alternator up by an amount of  $5,200 / 2,600 = \text{a factor of } 2$ . Therefore, the pulley on the engine should be twice the diameter of the pulley on the alternator.

The whole power plant can be built on a plywood base, and if a motorcycle battery is used to save weight, the unit can be quite small and easily portable, When the unit is producing the higher voltages, the battery provides the necessary rotor current. After a few hours of operation, it is advisable to throw the regulator back into the circuit and recharge the battery.

With simple modifications it is possible to charge 12 volt batteries. Quick batteries at 30 to 40 volts and high current, arc-weld at 50 to 60 volts, and run AC-DC appliances at 120 volts.

### **SPECIAL REGULATORS**

You may be interested in using an alternator to convert wind or water power to electricity. In such systems it is common practice to charge a bank of storage batteries, so that power is available even when the wind isn't blowing, or water levels are low.

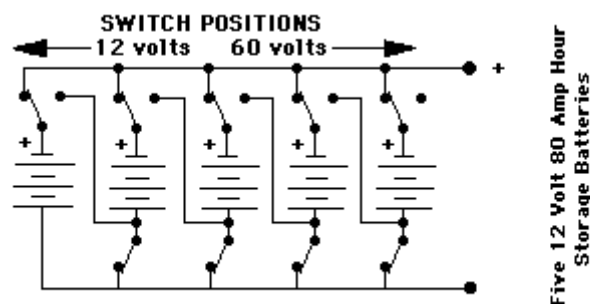

This arrangement allows five storage batteries to be charged as a single 60 volt 80 Amp-Hour battery, but provide 12 volt 400 amp-hour to drive inverters or appliances. Knife switches should be used to switch the bank. All switches should be brought to the open position, and then all switches should be moved to their new position. Most toggle switches will not work because they have no neutral position, and cannot handle heavy currents.

Most of these systems use 12 volts as standard which works well for average service, but seldom allows conversion of large amounts of available rotational energy.

Suppose, for example a windmill, waterwheel, or treadmill provides one horsepower of mechanical power to our 60 amp alternator. At 12 volts and 60 amps we get 720 watts out -- almost one horsepower.

Now suppose that more energy is available because of high winds or higher water head. The mill or wheel can now provide two horsepower, but because we cannot exceed 60 amps without overheating wiring or popping diodes. We only provide the maximum 720 watts at 12 volts. The additional horsepower is available, but can't be used with the 60 amp alternator.

Most storage banks are built from many batteries in parallel to provide 12 volts with at least 200 amp-hour capacity. Suppose that for those periods of high wind or water, that the batteries are connected to give a 36 volt battery pack and that the alternator is regulated by a special 36 volt regulator. Suppose, too, that we run the current all the way up-to 60 amps output. Now we are converting 36 volts X 60 amps, or 2,160 watts -- almost 3 horsepower. If the voltage could be run up to 120 volts, total watts at 60 amps would be 7,200 watts, ten times that available at 12 volts from the very same alternator.

At first impression you might think that the alternator could never handle it, but it can. Voltage is limited by the thickness of insulation on the windings and breakdown (PIV--peak inverse volts) voltage of the-diodes. Current through the windings and diodes produces heat. As long as the manufacturer's 'rated maximum current' is not exceeded, the windings and diodes will not overheat and melt. If you can provide the mechanical power at an excess of 5,000 shaft rpm, then you can extract the 7,200 watts without electrical damage. REMEMBER: The waste heat generated in both the diodes and windings is proportional to the current being produced whether it be at 12 or 120 volts.

Mechanical damage is another consideration. Since 7,200 watts is almost 10 horsepower, we must question the ability of the alternator bearings to handle this much power.

At this power level, a V-belt drive will not work for two reasons. First, the usual vehicle fan belt is too small to handle the load of 10 horsepower. It would snap under the tension. Second, V-belts require much friction on the sides of the pulley to transfer power, and this means the bearings are heavily loaded with a pull to one side. At 10 horsepower, they would probably wear out in a hurry. For these high power levels you'll have to consider chain and sprocket drive which can handle the higher power levels more efficiently with much less bearing loading.

High voltage regulators can be built with little difficulty. If it were not for the fact that most vehicle regulators are sealed, they could be simply modified. Nevertheless, the regulator circuits used on low voltage hobbyist power supplies will do the job. Schematics can be found in the electronics magazines, Radio Amateur's Handbook, and books on electronic power supplies. The basic design has been around for years.



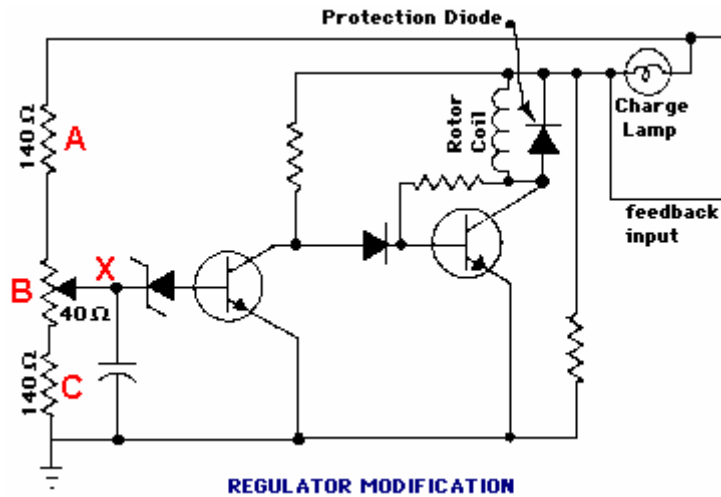

In the typical regulator circuit shown, the resistors **A**, **B** and **C** make up a circuit called a "voltage divider". It's function is to extract a fraction of the alternator output voltage and compare it to an internal voltage reference.

From ground to the high side in the diagram we have 140 + 40 + 140 ohms or 320 ohms total. If we assume that variable resistor **B** is set to 20 ohms, we see that from ground to point **X** we have 140 + 20 ohms or 160 ohms. Therefore, at point **X** we will see 160 / 320 or 1/2 of the high-side voltage. In other words, if the high side had 12 volts on it, measured from ground, we would see 6 volts at point **X** measured from ground. Moving the variable resistor arm closer to ground would lower the voltage at point **X**. The variable resistor selects the exact fraction or percentage of voltage that is to be compared to the internal reference.

Lets suppose the Zener diode, our internal reference, produces 6 volts. And let's assume that our voltage divider is set at 50%. When the high side is at 12 volts, the divider takes 50% or half, (6 volts) and compares that to the Zener voltage. Since the Zener is at 6 volts, there is no difference, and the regulator takes no action.

If high side drops to, say, 10 volts, then the divider takes half of that (5 volts) and compares that to the Zener voltage. Now we have a one-volt difference when compared to the unchanging 6-volt Zener voltage. This one-volt drop causes the transistors in the rest of the circuit which act as valves to open a little more and let more current into the rotor to increase the revolving magnetic field and bring output voltage back up. This continues until the high side voltage comes back up to 12.

If output voltage goes up, much the same thing happens. The difference between the voltage sample and the Zener is of opposite polarity, so the transistors shut off to the degree necessary to force alternator voltage back down. In practice these actions take place smoothly and continuously. Our explanation is simplified, but fairly accurate.

If you change the percentage setting of voltage divider resistors, you can change the alternator voltage. Suppose you change the divider setting so that 20% of voltage is extracted what would the output of the alternator be? To find out, divide the Zener reference voltage by the percentage:

$$\text{Output Volts} = \text{Zener Volts} / \text{Percentage, or, output Volts} = 6 \text{ volts} / 0.20 = 30 \text{ volts}$$

The regulator will take 30 volts, extract 20% with the voltage divider which comes to 6 volts. Comparing that with the Zener's 6 volts means that no corrective action will be taken. Any change from 30 volts will create a correction voltage that cause the transistors to open or close as necessary until voltage comes back to 30.

Suppose we set the voltage divider at 80%. What output voltage would we get from the alternator?

$$\text{Output Volts} = \text{Zener Volts} / \text{Percentage, or, output Volts} = 6 \text{ volts} / 0.80 = 7.5 \text{ volts}$$

In this case we've dropped from a 12 volt output to an output of just 7.5 volts.

The practical percentage ranges of voltage dividers usually run from 40% to 60%. This might translate into alternator output voltage settings of 10 to 15 volts.

To get beyond this range we need to change the Zener and perhaps the divider range as well. If we installed a 50-volt Zener diode. At a 50% divider setting, the output voltage would be  $50 / 0.50 = 100$  volts and if we again consider a practical 40% to 60% adjustment range, then the alternator could be regulated to produce a constant voltage in the 83 to 125 volt range.

The same resistors used for the 12 volt regulator could not be used in a high voltage regulator. At 120 volts, you'd be putting 10 times as much voltage across them, causing 10 times as much current to flow. Since power through a resistor is equal to the square of the current times ohms of resistance, you'd be putting 100 times more power into the resistors. In other words, they'd smoke and burn! In practice you'd probably want to increase the resistance 100 times. That would limit the current flow and power into resistors to its original value when run at 12 volts.

It is not the purpose of this manual to be a course in electronics design. The principles involved in designing and building a basic electronic regulator can be found in a great many books on electronics and power supply design. You should read up on the subject before designing a regulator. One good book worth consulting is *Regulated Power Supplies* by Irving M Gottlieb, published by Howard W Sams, Indianapolis IN. There are many others.

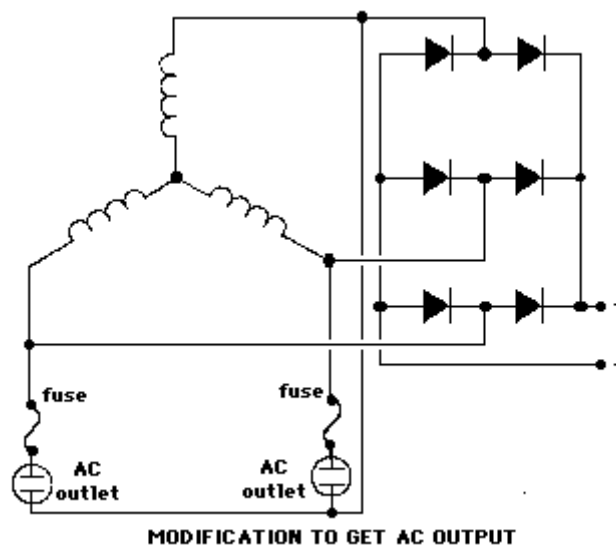

### **MODIFICATION FOR 110 VOLT AC**

Alternators produce rectified DC power. If we tap the leads attached to the diodes, we can obtain 120 volt AC power. Some, but not all transformer operated appliances such as TV's, radio's, fluorescent lights might be possibly be run on this AC.

AC coming from the alternator is very high frequency and a great many transformers will overheat at the high frequency. The only way to tell is to plug the device in for a few seconds, unplug it, and then feel the transformer or ballast to see if it is overheating. Even this is risky. Unless you're willing to take the chances involved, you might be better off converting an induction motor to provide pure 60 cycle AC, described later on. If you'd still like to give it a try, conversion is a simple matter of removing diodes, and connecting leads. In most alternators two wires are soldered to each of the diodes. Remove both from the diode and attach it to one of three leads. When wired as shown, two outlets with a common ground can be powered.

Forget about running motor-driven appliances-unless they use universal AC-DC brush type motors. Ordinary induction motors are designed for 60 cycles AC. At different frequencies they will run at different rpm if at all, and will quite possibly overheat or be destroyed.

### **REWINDING FOR WINDMILL USE**

Alternators usually loaf along at low rpm, and do not usually begin to produce a lot of power until they exceed about 1,000 rpm. This rpm limit can be lowered by rewinding the alternator's stationary coils. An alternator modified in this way used on a windmill, for instance, can begin to produce power at a lower wind speed, producing greater total power output over a period of time.

For example, a 45 amp Chrysler alternator can be modified by removing each of the 16 turn coils, and by replacing them with a smaller diameter wire so that each coil is made up of more turns. AWG #20 plastic coated wire (such as Belden polythermaleze) obtained from a motor shop can be used to wind coils of 25 to 26 turns before all available slot space is used. These coils are then set by dipping in motor varnish and baking with low heat until hardened. Small diameter wire reduces maximum current available. Here, No. 20 will handle only about 25 amps with good cooling, but the extra windings allow the alternator to begin charging at a much lower rpm. One good reference on motor and generator rewinding is *Armature Winding and Motor Repair* by Daniel Breymer available from Lindsay Publications.

### **BUILDING A 60 CYCLE ALTERNATOR**

Theory says that any generator can be used as a motor and vice-versa. If this is so, could we take a common 1/3 hp induction washing machine motor and use it to produce 120 volts 60 cycle power? The answer is yes! But we have two problems to solve. First, we must drive the motor faster than its nameplate rpm to get a 60 cycles per second output. Second, when we start the unit, we may have to hit the coils with a DC pulse to start it generating.

Induction motors have no physical connection between the stationary winding and the squirrel cage rotor. The electricity flowing in the rotor is created by transformer action because the magnetic field in the stator winding is revolving at 1,800 rpm while the rotor is revolving at 1,725 rpm. The 75 rpm difference (4 to 5%) causes a current to be induced in the rotor.

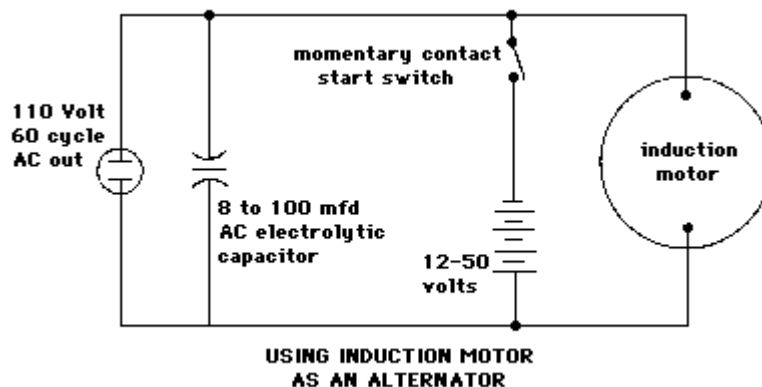

When used as an alternator, the motor must be driven 4-5% faster than the 1,800 rpm synchronous speed. This comes to about 1,880 rpm, faster or slower depending on alternator loading. When the driving speed is exactly right, the alternator will be producing exactly 60 cycles per second output power.

Some motors will begin generating power as soon as they're driven because there's a small amount of residual magnetism remaining in the rotor and windings. If generation doesn't begin by itself, you'll probably have to hit the windings with a pulse of DC current to get it started. A switch connected to a 12 volt battery will probably be adequate, although in some cases you may need as much as 60 volts to do the job.

A split-phase capacitor-run motor can be used just as it is, but other motors will probably need a capacitor in the 8 to 100 microfarad range. Trial and error will determine the exact size. Make sure the capacitors are rated at 250 to 300 volts AC.

Not all motors will work properly, and we don't really know why. Fortunately, most motors do. You won't be able to get as much power out of the motor as the nameplate indicates. To find exactly how much power you can get, connect ordinary light bulbs to your new alternator one after another. At some point the alternator will suddenly stop working, indicating that it is overloaded. This response can sometimes be a hassle, but it makes the alternator "burn-out proof".

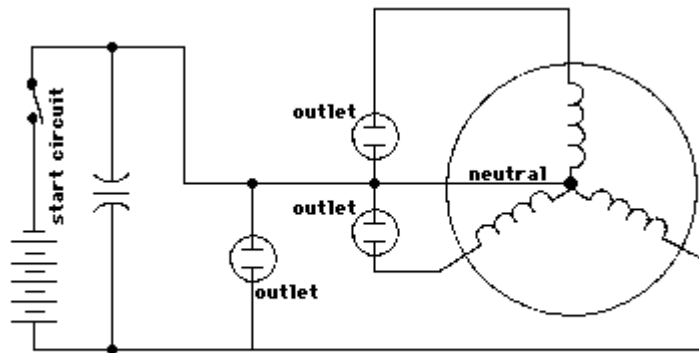

**THREE PHASE STAR MOTOR WITH NEUTRAL**  
 each outlet delivers 220 VAC at 60 Hz

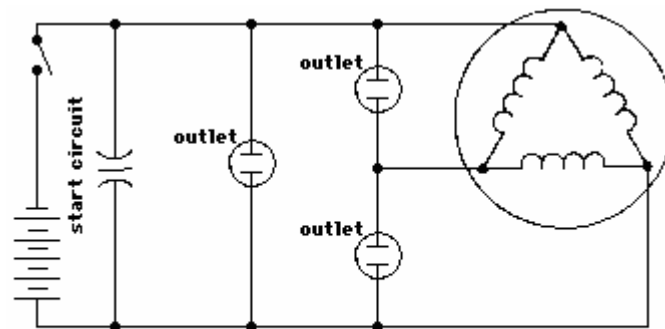

**THREE PHASE DELTA MOTOR**  
 each outlet delivers  
 208 or 220 VAC at 60 Hz

To get large amount of AC out, you will need a large motor --- over a horsepower. You may be able to find a large single phase motor on a table saw or on farm machinery. But you may have to use a three-phase motor. With a three-phase machine you'll need a capacitor across one of the legs, but not on all three. Remember though, three-phase motors will generate power from 208 volts on up. To get 110 volts you'll have to use a large transformer to step the 208 volts down to 110 volts, and that's not very practical.

The frequency of the AC out will vary as the engine rpm varies. How are you going to know when you have 60 cycles per second? One easy way is to use a motor driven clock. Plug it into the circuit and leave it there. It only draws a few watts. Compare the second hand with the seconds counter on a quartz wrist watch. If the motor clock is running slow, the AC is less than 60 cycle. Adjust engine rpm until the clock is keeping accurate time.

In conclusion, you can generate small amounts of 120 volt 60 cycles per second power which will drive anything from your US TV to your refrigerator using an induction motor as an alternator. It will take experimentation. When it works (which is most of the time), it works very well. It's certainly worth trying.

\*\*\*\*\*

Patrick Kelly  
[engpjk@yahoo.co.uk](mailto:engpjk@yahoo.co.uk)  
<http://www.free-energy-info.co.uk>  
<http://www.free-energy-info.com>